

STANDARD AND DRAFT STYLE UNITS ONLY
CABINET SHOWN WITH NO DOORS

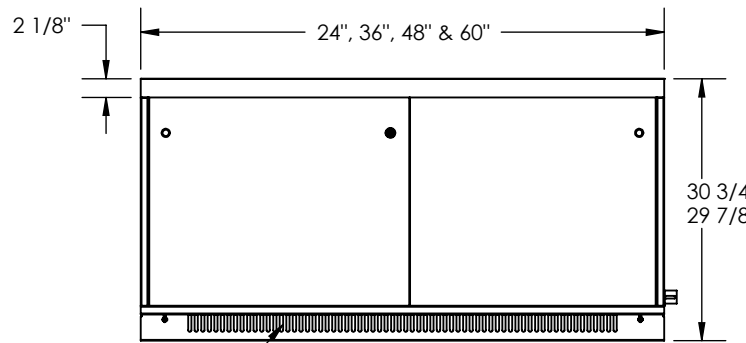

AIR INLET SLOTS PROVIDED ON RADIATION STYLE ONLY
CABINET SHOWN WITH LOCKING DOORS

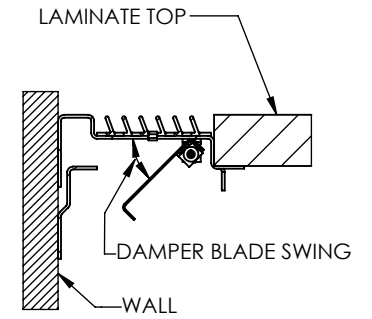

NOTE
DAMPER CONTROL ASSEMBLY ON DRAFT-STOP MODELS ONLY

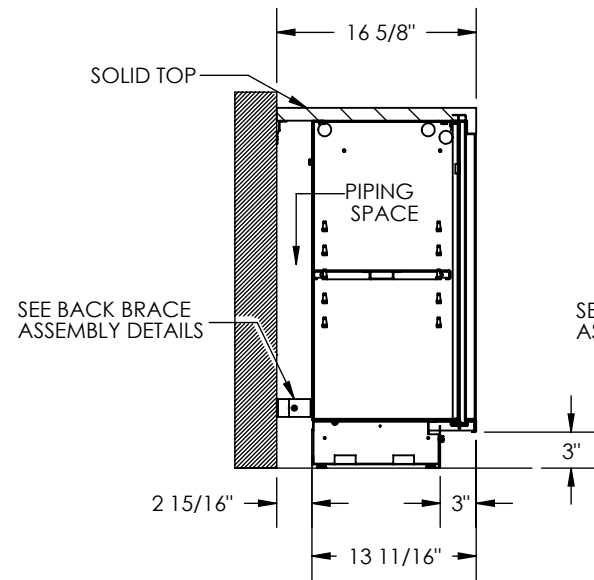

11-1/2" SHELF
STANDARD UNIT W/PIPE CHASE

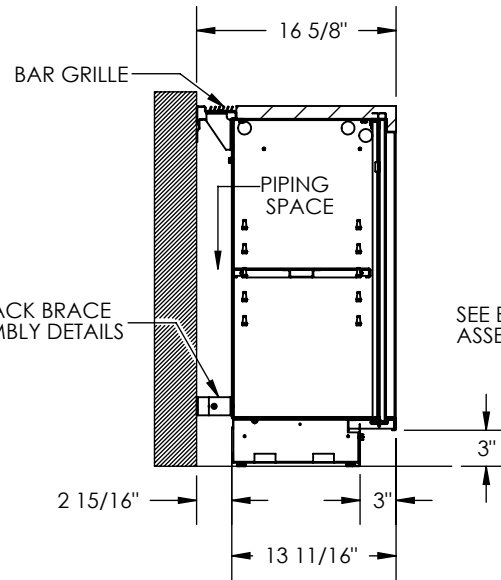

11-1/2" SHELF
RADIATION UNIT

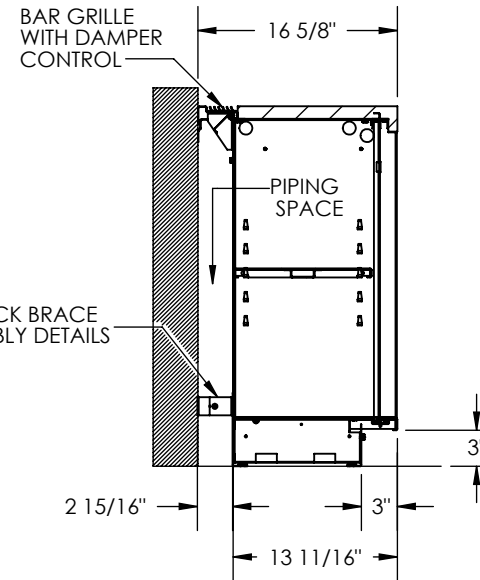

11-1/2" SHELF
DRAFTSTOP UNIT

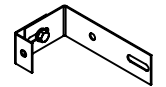

16-5/8"
DETAIL SHOWN OF THE
BACK BRACE ASSEMBLY

CONTRACTOR _____
ARCHITECT _____
ENGINEER _____
REPRESENTATIVE _____
LOCATION _____

zehnder
Rittling

BUFFALO,
NEW YORK 14220

JOB: _____

CABINETS WITH LAMINATED TOPS

DATE: 07/15/11

DWG.NO. 04ZCL-16

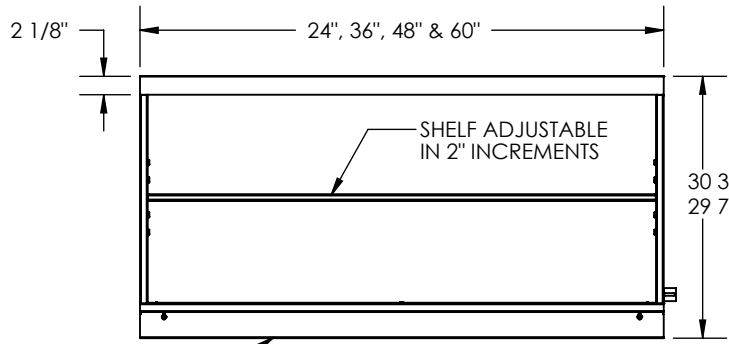

STANDARD AND DRAFT STYLE UNITS ONLY
CABINET SHOWN WITH NO DOORS

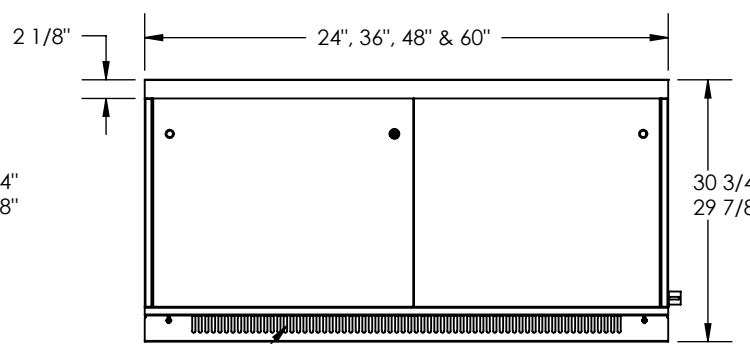

AIR INLET SLOTS PROVIDED ON RADIATION STYLE ONLY
CABINET SHOWN WITH LOCKING DOORS

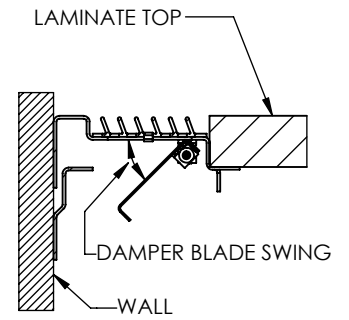

NOTE
DAMPER CONTROL ASSEMBLY ON DRAFT-STOP MODELS ONLY

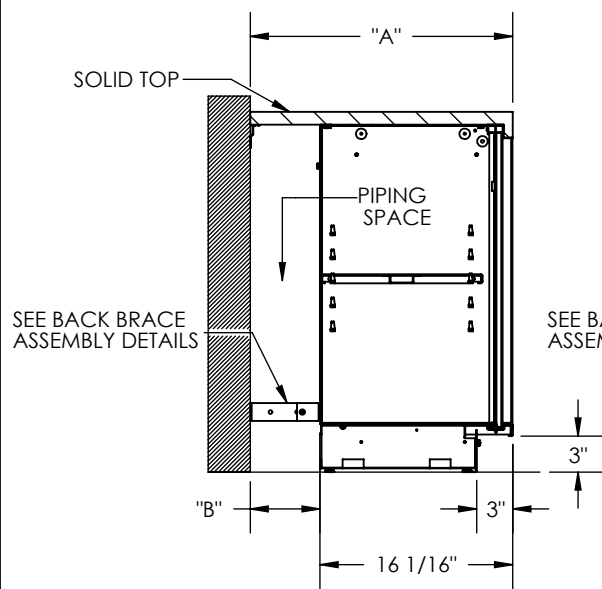

13-1/2" SHELF
STANDARD UNIT W/PIPE CHASE

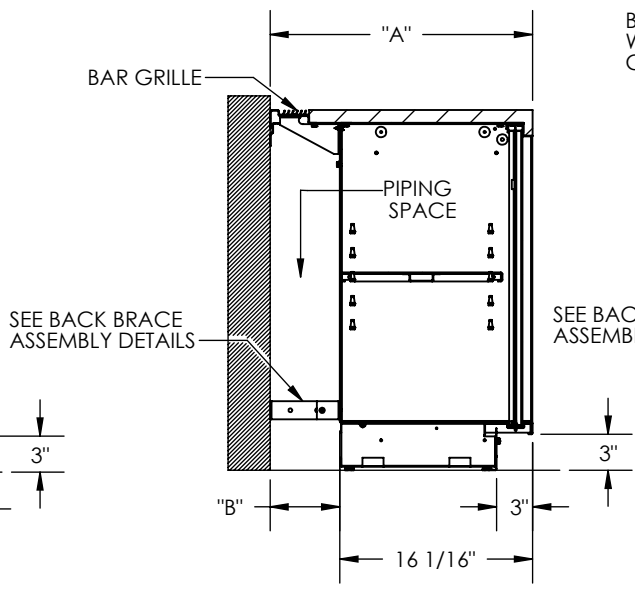

13-1/2" SHELF
RADIATION UNIT

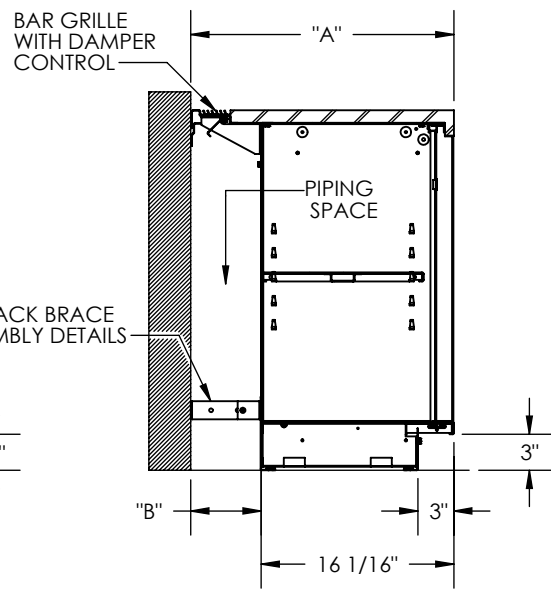

13-1/2" SHELF
DRAFTSTOP UNIT

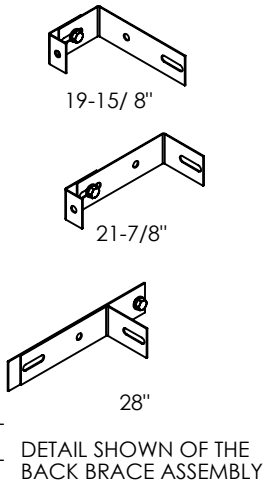

DETAIL SHOWN OF THE BACK BRACE ASSEMBLY

CONTRACTOR _____
ARCHITECT _____
ENGINEER _____
REPRESENTATIVE _____
LOCATION _____

CABINETS WITH LAMINATED TOPS	
CABINET DEPTH "A"	PIPING SPACE "B"
19-5/8"	3-9/16"
21-7/8"	5-13/16"
28"	11-15/16"

zehnder Rittling
BUFFALO, NEW YORK 14220
JOB: _____
DATE: 07/15/11 DWG.NO. 04ZCL-19-21-28

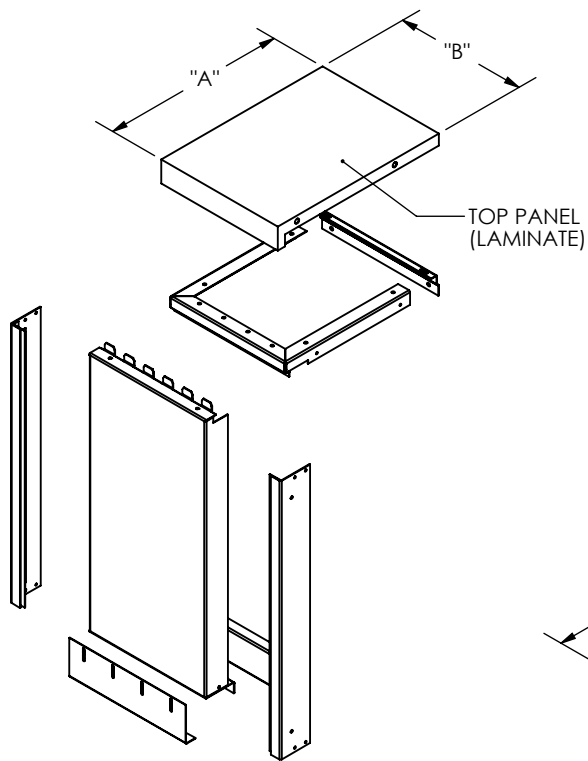

FILL SECTION

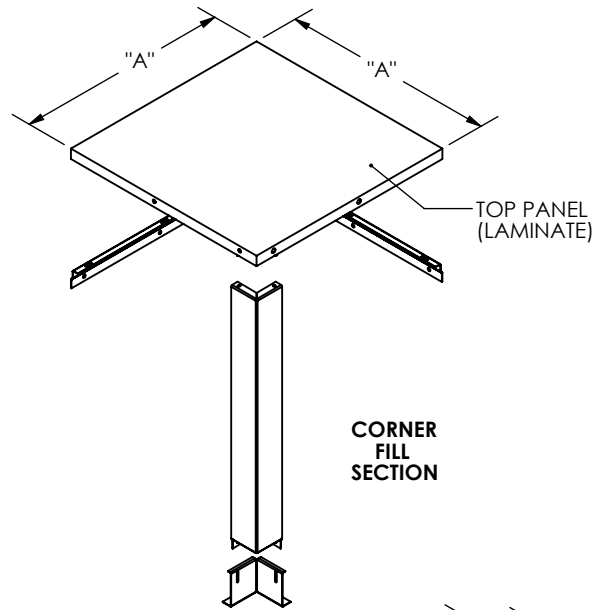

CORNER FILL SECTION

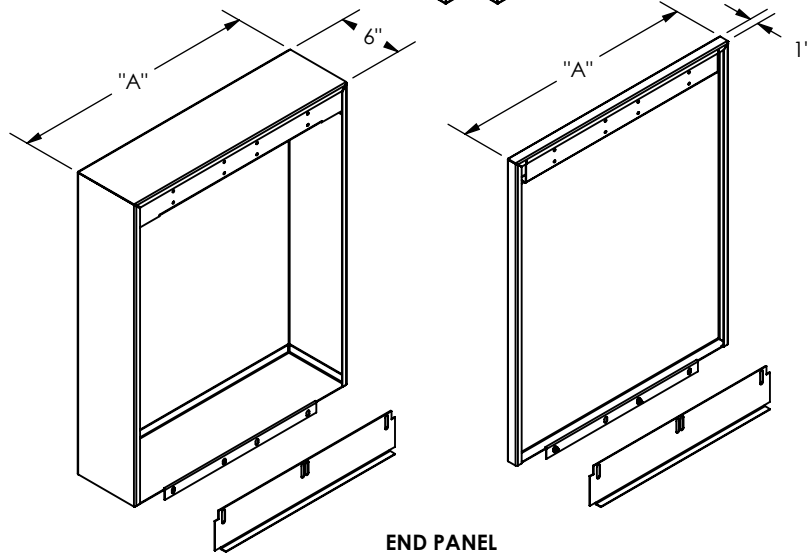

END PANEL

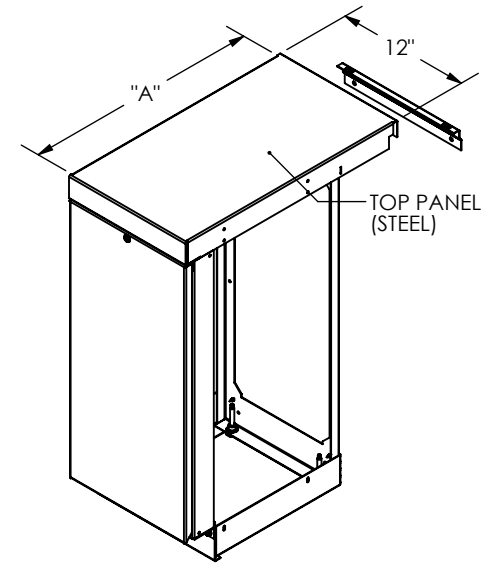

UTILITY COMPARTMENT
(SHIPPED FULLY ASSEMBLED)

NOTE: END PANELS WILL FIT PAINTED AND LAMINATED TOP STORAGE CABINETS AND UTILITY COMPARTMENT.

ACCESSORIES FOR LAMINATE TOP CABINETS

CONTRACTOR _____	"A"	"B"	zehnder Rittling	BUFFALO, NEW YORK 14220
ARCHITECT _____	16-5/8"	18" & 24"		
ENGINEER _____	19-5/8"	18" & 24"	JOB: _____	
REPRESENTATIVE _____	21-7/8"	18" & 24"	DATE: 07/15/11	
LOCATION _____	28"	18" & 24"	DWG.NO. 04ZC-ACC-2	

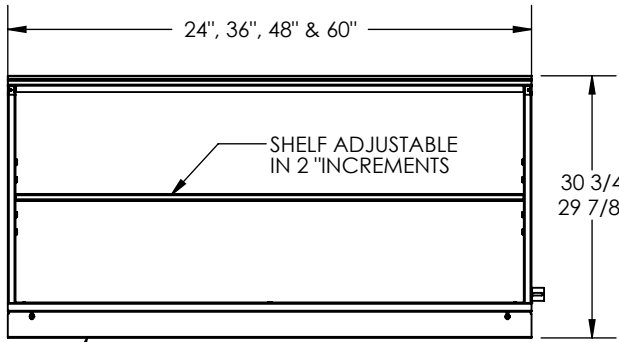

STANDARD AND DRAFT STYLE UNITS ONLY

CABINET SHOWN WITH NO DOORS

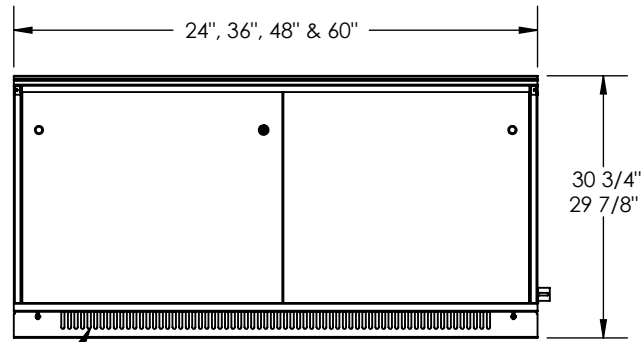

AIR INLET SLOTS PROVIDED ON RADIATION STYLE ONLY

CABINET SHOWN WITH LOCKING DOORS

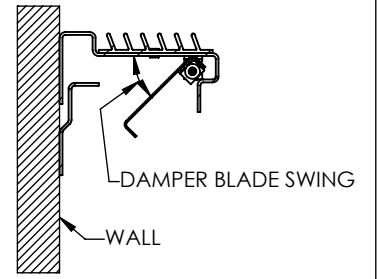

NOTE
DAMPER CONTROL ASSEMBLY ON DRAFT-STOP MODEL ONLY

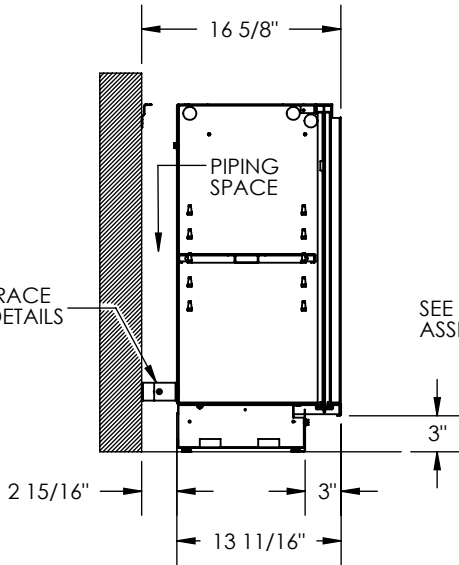

SEE BACK BRACE ASSEMBLY DETAILS

11-1/2" SHELF
STANDARD UNIT W/PIPE CHASE

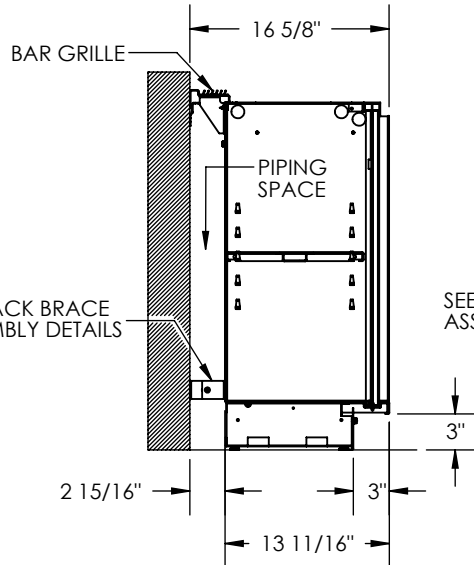

SEE BACK BRACE ASSEMBLY DETAILS

11-1/2" SHELF
RADIATION UNIT

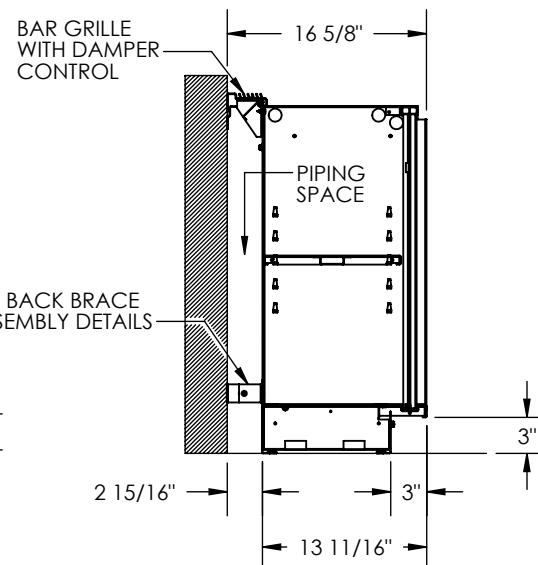

SEE BACK BRACE ASSEMBLY DETAILS

11-1/2" SHELF
DRAFT-STOP UNIT

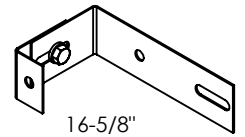

DETAIL SHOWN OF THE
BACK BRACE ASSEMBLY

CONTRACTOR _____
ARCHITECT _____
ENGINEER _____
REPRESENTATIVE _____
LOCATION _____

zehnder
Rittling

**BUFFALO,
NEW YORK 14220**

JOB: _____

CABINETS WITH NO TOPS

DATE: 07/15/11

DWG.NO. 04ZCN-16

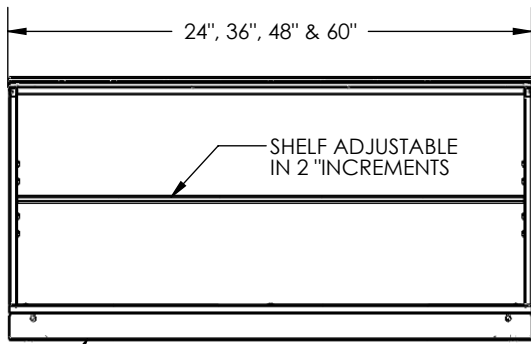

STANDARD AND DRAFT STYLE UNITS ONLY

CABINET SHOWN WITH NO DOORS

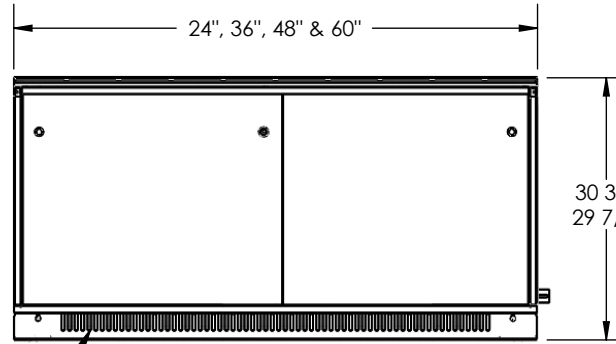

AIR INLET SLOTS PROVIDED ON RADIATION STYLE ONLY

CABINET SHOWN WITH LOCKING DOORS

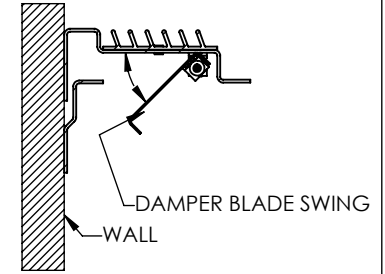

NOTE
DAMPER CONTROL ASSEMBLY ON DRAFT-STOP MODEL ONLY

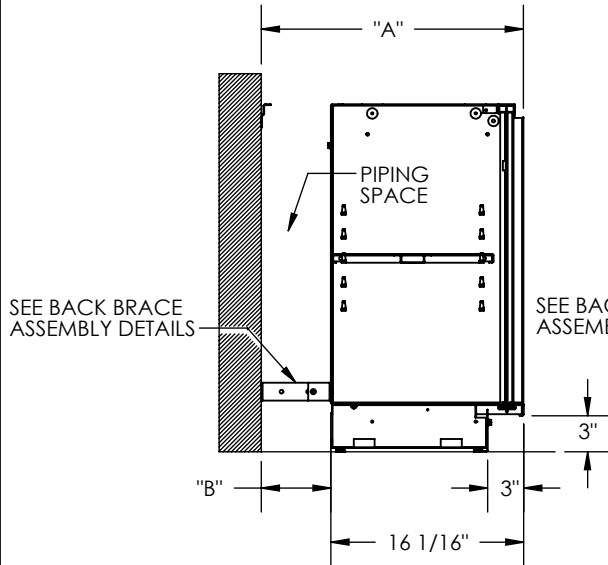

13-1/2" SHELF
STANDARD UNIT W/PIPE CHASE

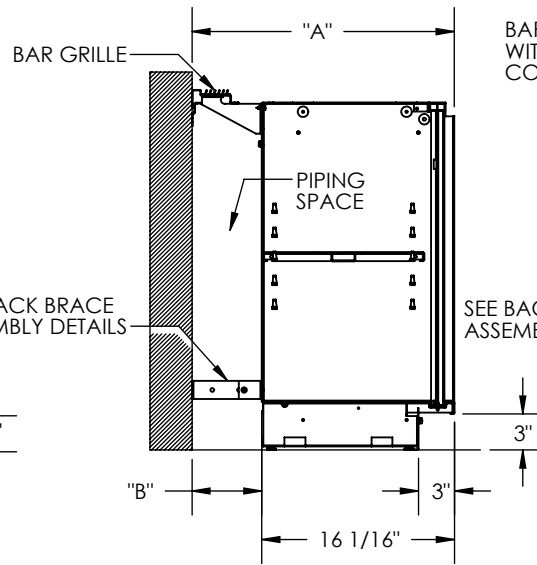

13-1/2" SHELF
RADIATION UNIT

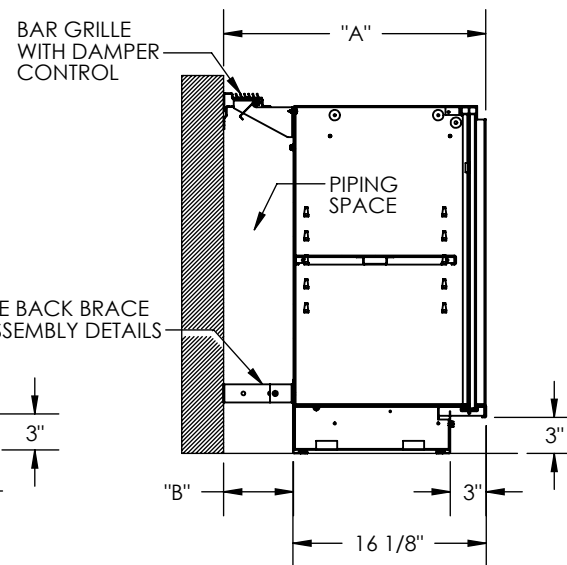

13-1/2" SHELF
DRAFT-STOP UNIT

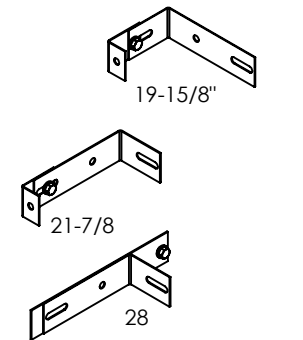

DETAIL SHOWN OF THE BACK BRACE ASSEMBLY

CONTRACTOR _____
 ARCHITECT _____
 ENGINEER _____
 REPRESENTATIVE _____
 LOCATION _____

CABINETS WITH NO TOPS	
CABINET DEPTH "A"	PIPING SPACE "B"
19-5/8"	3-9/16"
21-7/8"	5-13/16"
28"	11-15/16"

zehnder Rittling
 BUFFALO, NEW YORK 14220
 JOB: _____
 DATE: 07/15/11 DWG.NO. 04ZCN-19-21-28

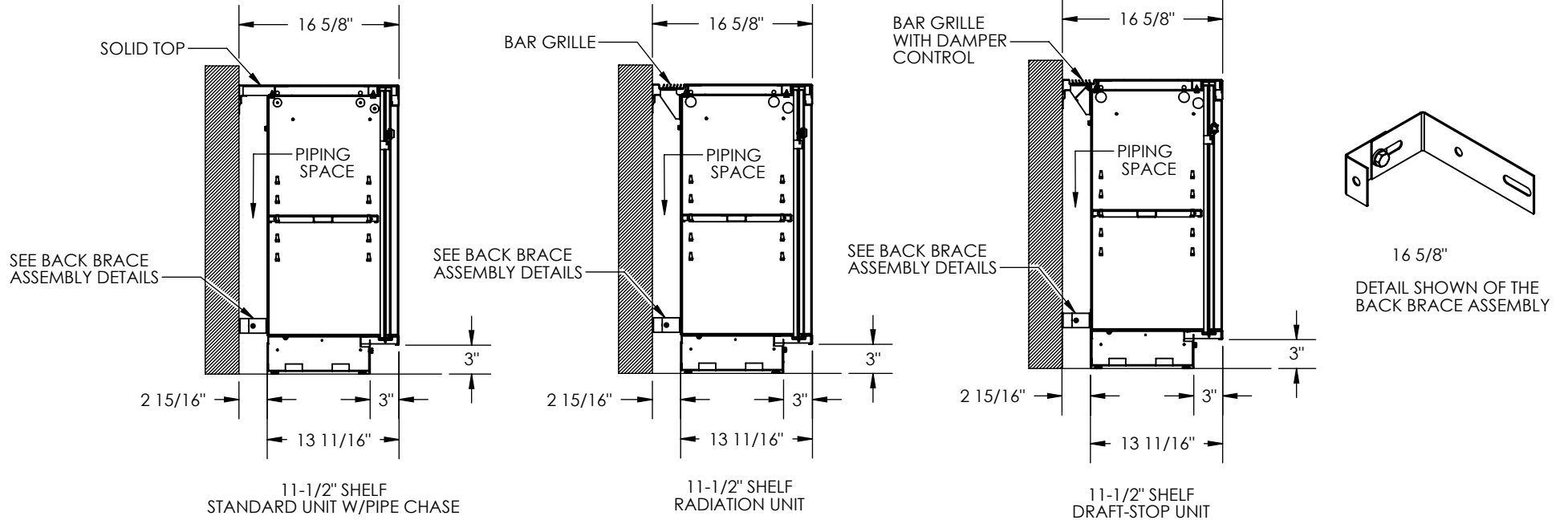
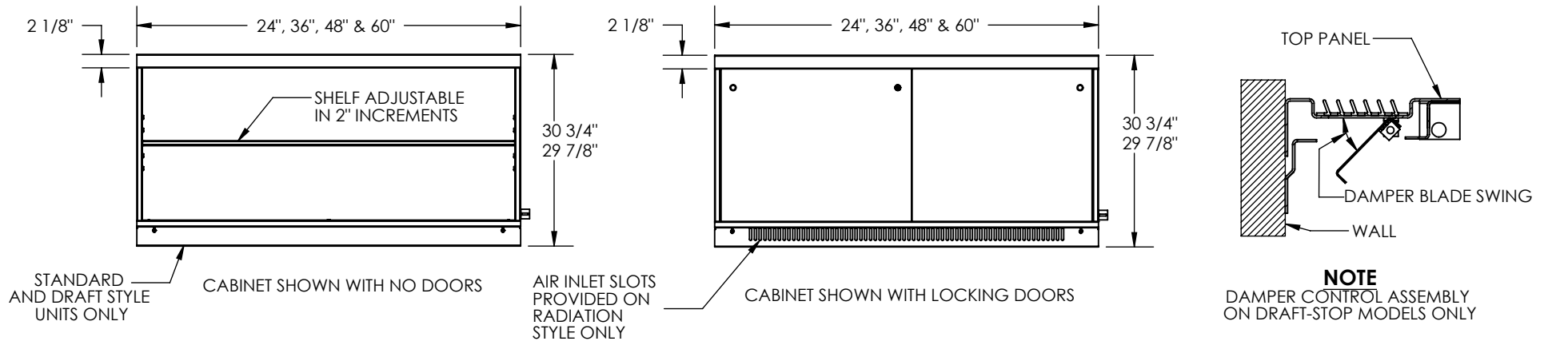

CONTRACTOR _____
 ARCHITECT _____
 ENGINEER _____
 REPRESENTATIVE _____
 LOCATION _____

CABINETS WITH PAINTED STEEL TOPS

zehnder Rittling
 BUFFALO, NEW YORK 14220

JOB: _____

DATE: 07/15/11 DWG.NO. 04ZCP-16

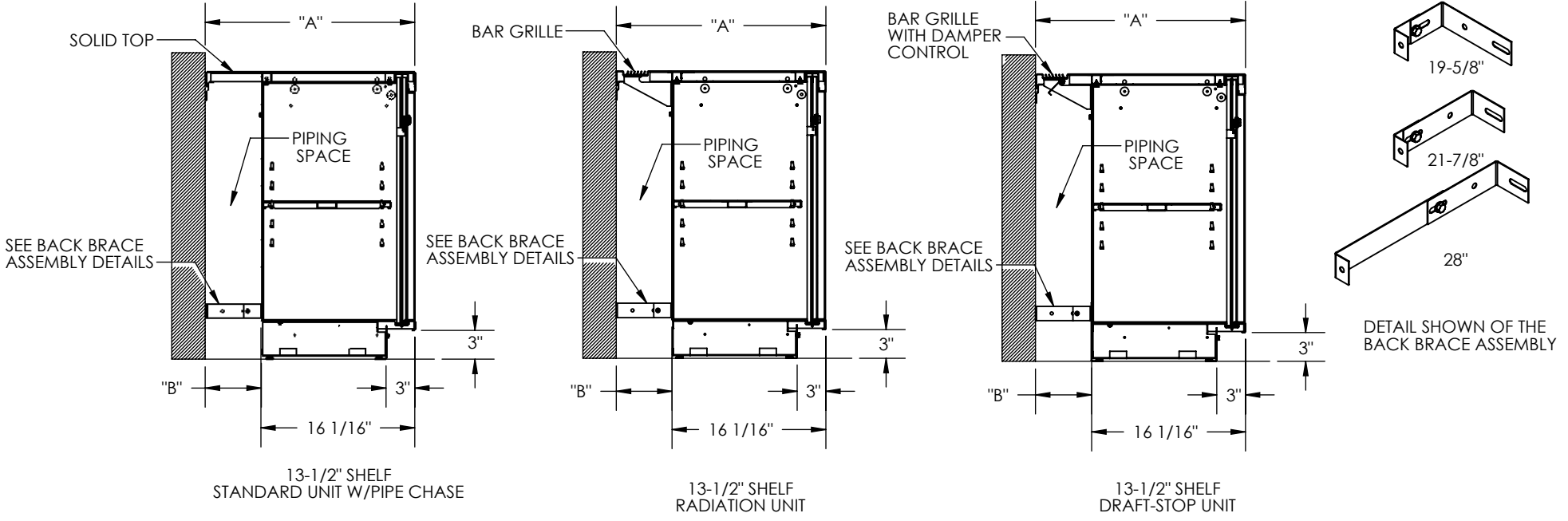
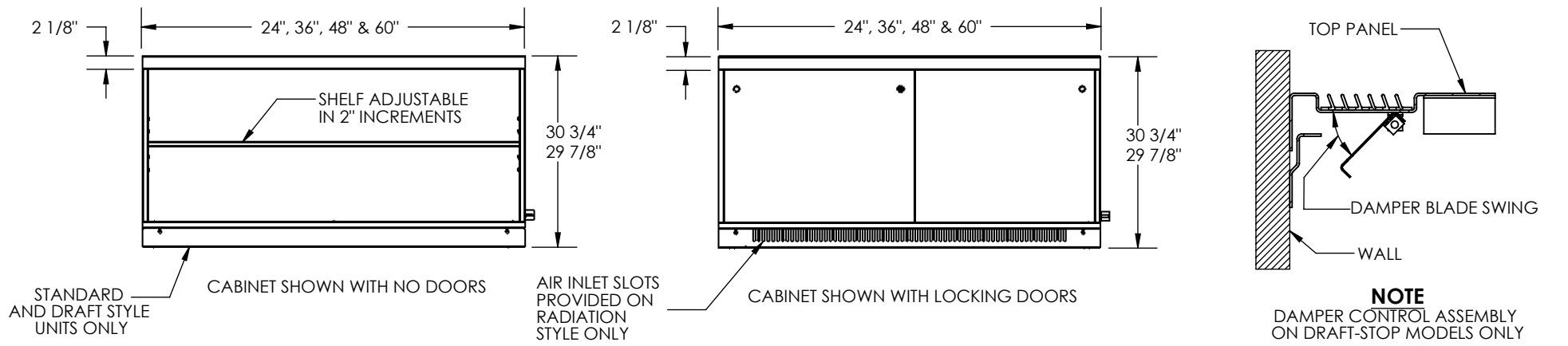

CONTRACTOR _____	CABINETS WITH PAINTED STEEL TOPS		zehnder Rittling	BUFFALO, NEW YORK 14220
ARCHITECT _____	CABINET DEPTH "A"	PIPING SPACE "B"		
ENGINEER _____	19-5/8"	3-9/16"		
REPRESENTATIVE _____	21-7/8"	5-13/16"		
LOCATION _____	28"	11-15/16"	DATE: 07/15/11	DWG.NO. 04ZCP-19-21-28

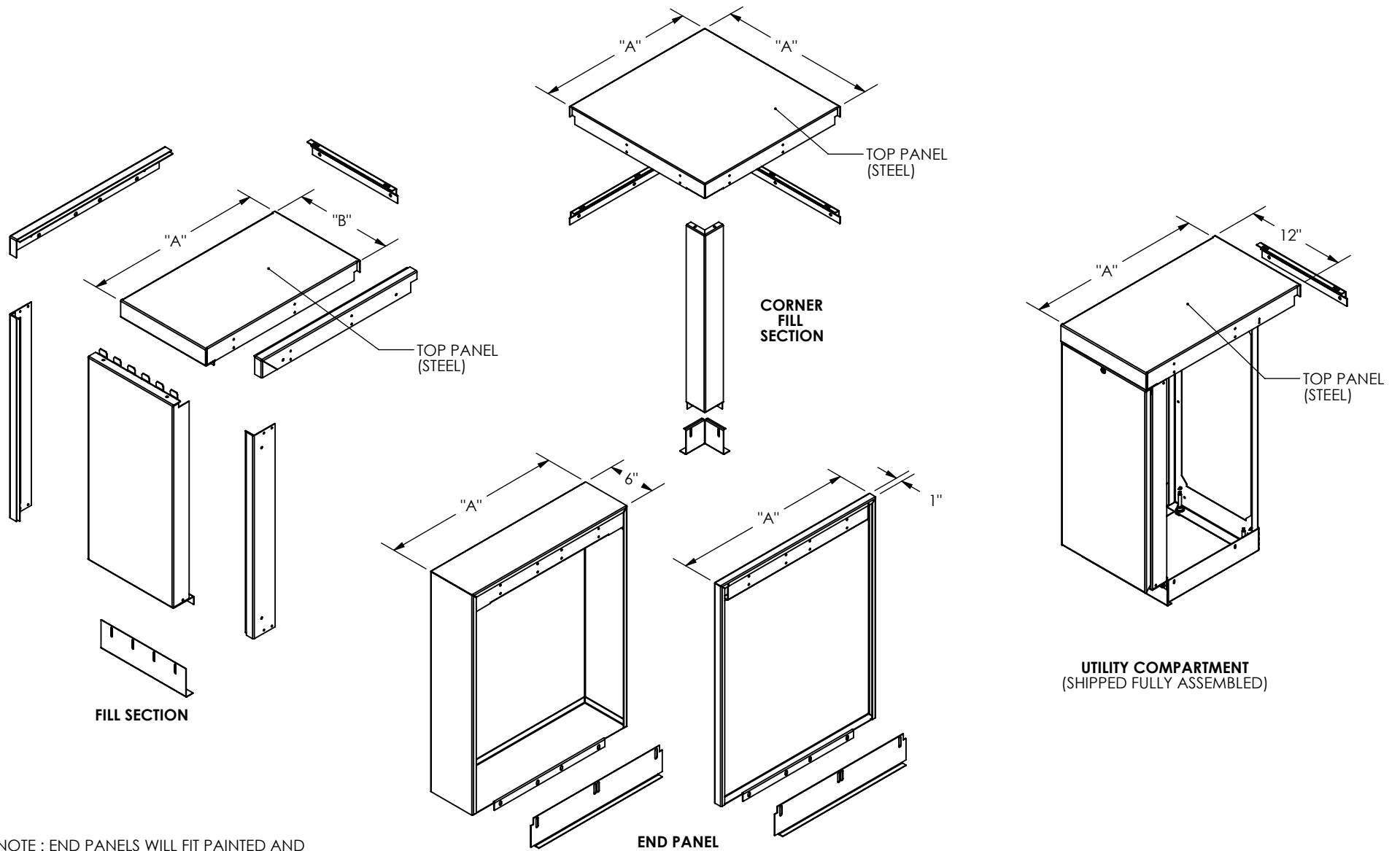

NOTE : END PANELS WILL FIT PAINTED AND LAMINATED TOP STORAGE CABINETS AND UTILITY COMPARTMENT.

ACCESSORIES FOR PAINTED STEEL TOP CABINETS

CONTRACTOR _____	"A"	"B"	zehnder Rittling	BUFFALO, NEW YORK 14220
ARCHITECT _____	16-5/8"	18" & 24"		
ENGINEER _____	19-5/8"	18" & 24"	JOB: _____	
REPRESENTATIVE _____	21-7/8"	18" & 24"	DATE: 07/15/11	
LOCATION _____	28"	18" & 24"	DWG.NO. 04ZC-ACC-1	