

Integrated Radiant Metal Ceiling Solutions

Catalog





Zehnder decorative radiators



Heating and cooling ceiling systems



Comfortable indoor ventilation



Clean air solutions

zehnder

always the
best climate

Always the best climate for

IMPROVED QUALITY OF LIFE

With Zehnder, you will find the perfect climate for any space.

www.zehnder-systems.com



Complete cooling and heating ceiling system solutions

Customers can now order a fully suspended heating and cooling ceiling from Zehnder in a variety of versions. The aesthetically pleasing appearance and perfect fit of the suspended ceiling systems are complemented by the following features:

- Very high heating and cooling performance
- Comfortable indoor climate thanks to high proportion of radiation
- Short reaction time to temperature changes in the room
- Tailored ceiling system - maximum freedom of design
- Ceiling void can be accessed quickly
- Perforated version delivers good sound absorption
- Integration of functional elements (lights, smoke detectors, air outlets, etc.)

The Zehnder heating and cooling ceiling systems offer maximum convenience and a highly energy-efficient solutions especially for use in office buildings, schools, hospitals and public buildings.

Suspended ceiling systems	2
Wall connections	12
Surface and colors	14
Perforation	14
Sound absorption	15
Activation	16
Connection options	18
Connector technology	18
Special solutions	19
Technical data	20
Applications	22
The one-stop custom solutions	24
Warranty	26

C-Channel grid system

The C-Channel grid system allows post installation modifications to the room geometry. The modules are placed on wide support tracks (strips). This allows easy retrofitting of partition walls.

Flexibility and time-savings are essential benefits, particularly when re-planning a room.

Inspection/modification is possible for each cassette. This ensures quick access to the ceiling void.

The C-Channel grid system is ideally suitable for use with larger module sizes (max. 16 ft²).

No special tools are required to open and close the ceiling panels.



Further information:

Sound absorption	15
Technical data	21

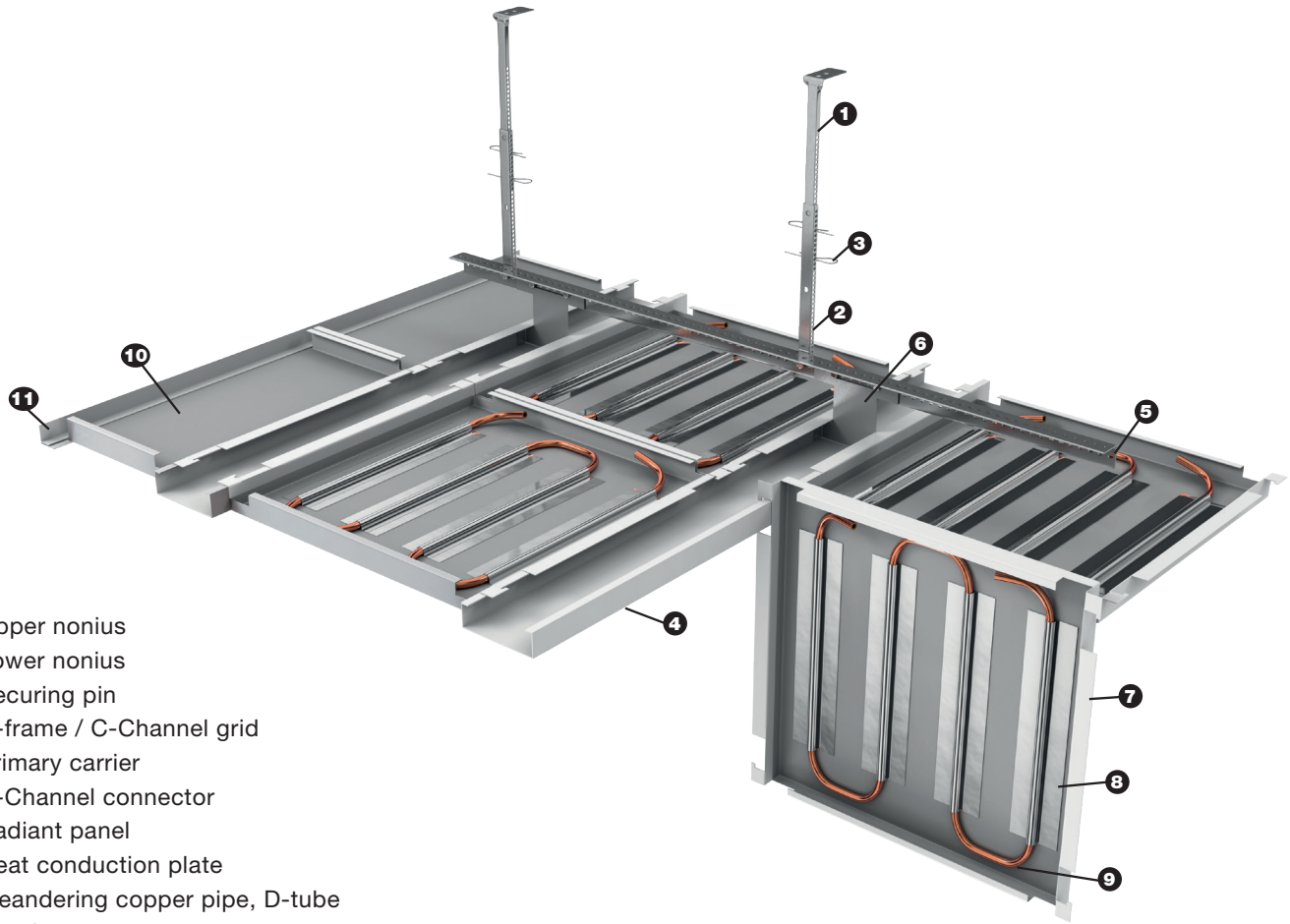

1. Upper nonius
2. Lower nonius
3. Securing pin
4. C-frame / C-Channel grid
5. Primary carrier
6. C-Channel connector
7. Radiant panel
8. Heat conduction plate
9. Meandering copper pipe, D-tube
10. Inactive cassette
11. Wall channel

C-Channel system	
Maximum panel length [in]	≤ 78
Maximum panel width [in]	≤ 51
Maximum recommended surface area / panel [ft ²]	16
Activation ¹	Aluminium
Concealed substructure	-
Non-lift-out feature	-
Inspection / modification possible	▪
Hinges down	▪
Suitable for subsequent modifications to room geometry	▪
Sound absorption (perforated) $\alpha_s = 0.55-0.95$	▪
Allows installation of other features (lights, ventilation, etc.)	▪
Special colors	▪

¹ Other activations on request

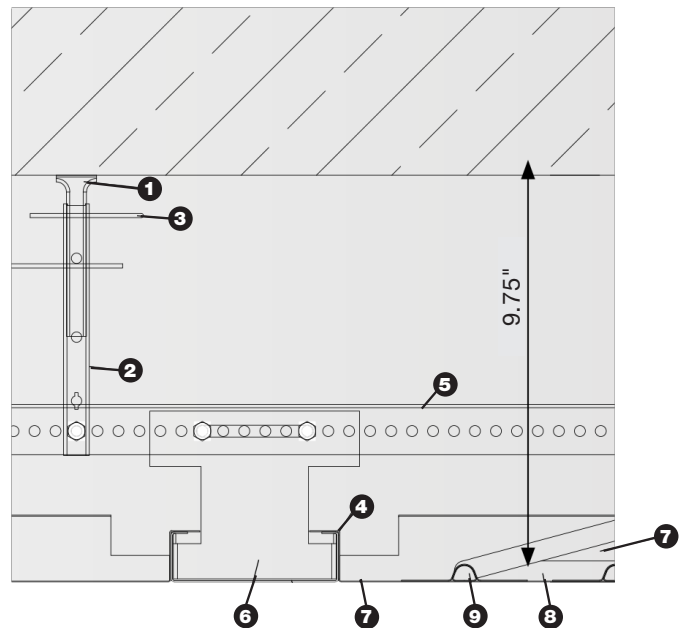

Clip-in system

The clip-in system has an invisible substructure for an attractive appearance. The ceiling void is ideal for use as an installation level.

The hinge-down modules make retrofitting fast and simple.

The anti-lift out installation versions ensure a secure fit in the support structure.

The modules clamp into the concealed clamping rail in the substructure. The system is suitable for use with smaller module sizes (max. 8.6 ft²).



Further information:

Sound absorption	15
Technical data	21

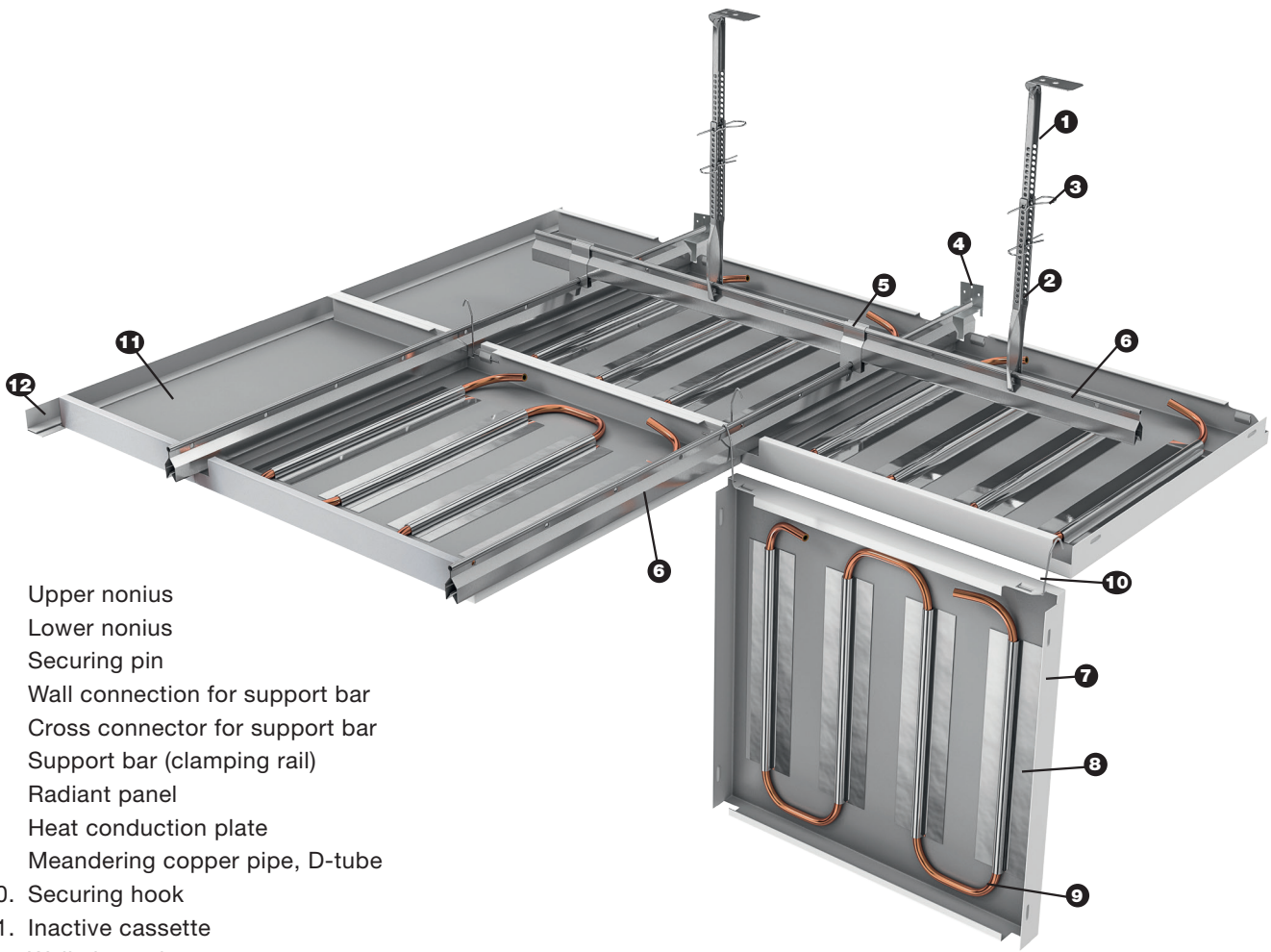

Clip-in system	
Maximum panel length [in]	≤ 78
Maximum panel width [in]	≤ 47
Maximum recommended surface area / panel [ft ²]	8.6
Activation ¹	Aluminium
Concealed substructure	▪
Non-lift-out feature	▪
Inspection / modification possible	▪
Hinges down	▪
Suitable for subsequent modifications to room geometry	-
Sound absorption (perforated) $\alpha_s = 0.55-0.95$	▪
Allows installation of other features (lights, ventilation, etc.)	▪
Special colors	▪

¹ Other activations on request

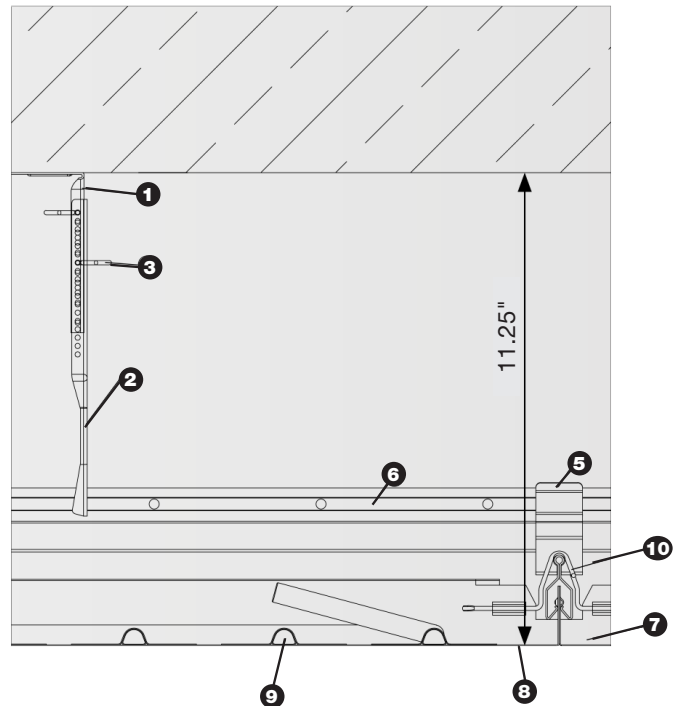

Hook-on system

The hook-on system has an invisible substructure and blends ideally with any design concept.

The ceiling void is ideal for use as an installation level. The modules fold down quickly and easily at any time.

The anti-lift out installation versions ensure a secure fit in the support structure.

The modules hook onto the invisible substructure. The system is suitable for use with larger module sizes (max. 18.25 ft²).



Further information:

Sound absorption	15
Technical data	21

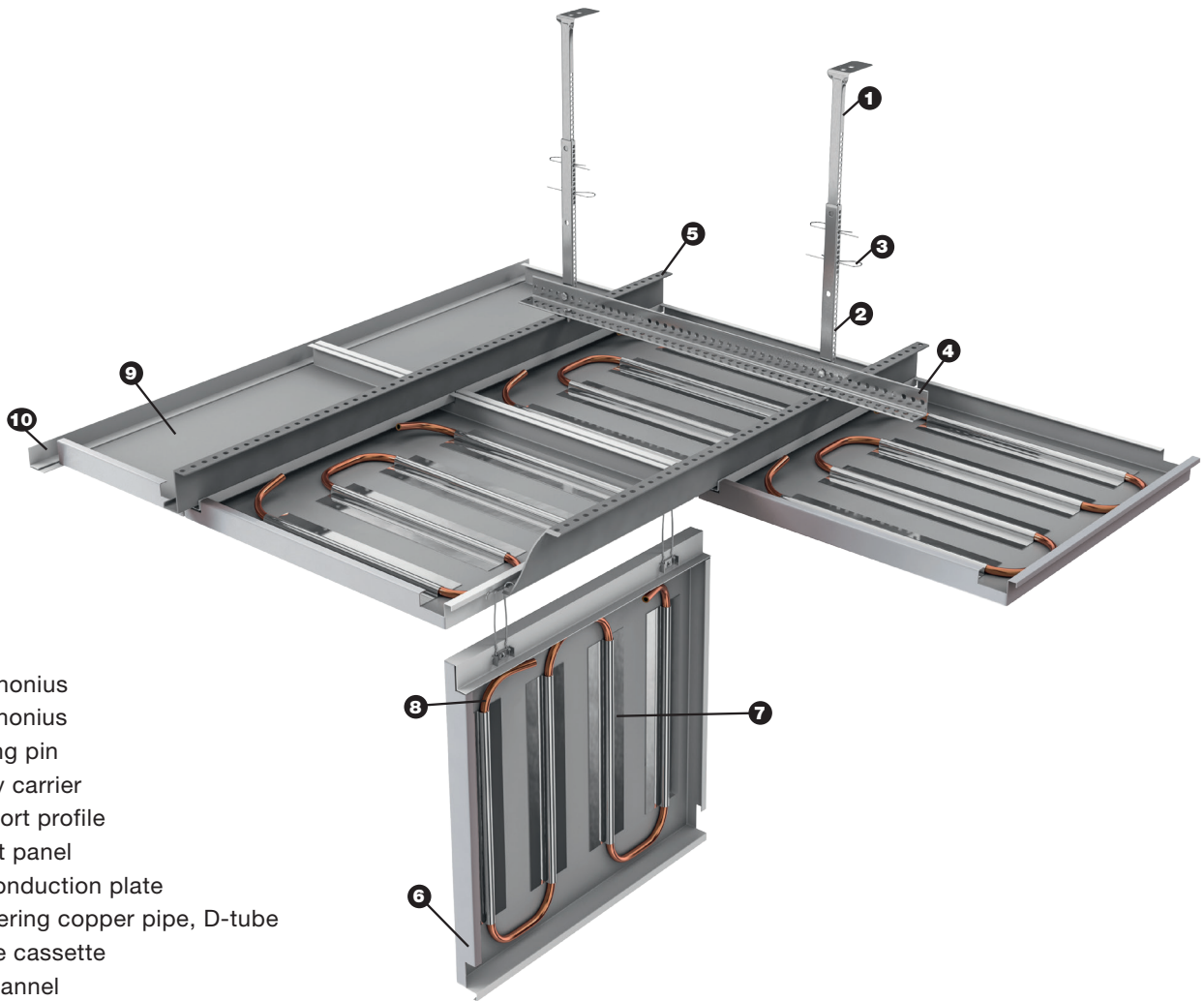

1. Upper nonius
2. Lower nonius
3. Securing pin
4. Primary carrier
5. Z-support profile
6. Radiant panel
7. Heat conduction plate
8. Meandering copper pipe, D-tube
9. Inactive cassette
10. Wall channel

Hook-on system	
Maximum panel length [in]	≤ 78
Maximum panel width [in]	≤ 51
Maximum recommended surface area / panel [ft ²]	18.25
Activation ¹	Aluminium
Concealed substructure	▪
Non-lift-out feature	▪
Inspection / modification possible	▪
Hinges down	▪
Suitable for subsequent modifications to room geometry	-
Sound absorption (perforated) $\alpha_s = 0.55-0.95$	▪
Allows installation of other features (lights, ventilation, etc.)	▪
Special colors	▪

¹ Other activations on request

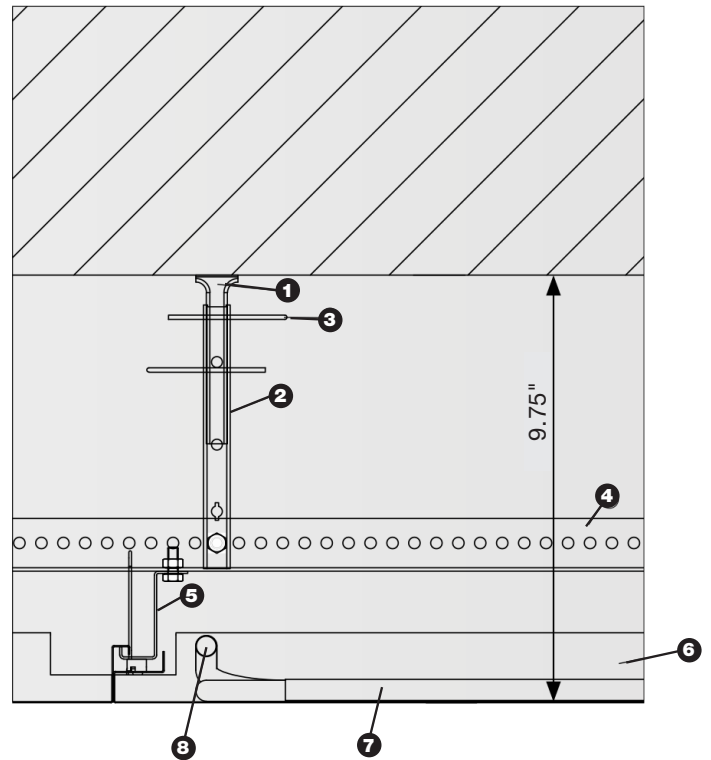

Lay-in system

The lay-in system is specially tailored for use in new or existing grid ceilings.

The available basic grid dimensions is 23.62". The lay-in modules come in five standard lengths. The length of these various lay-in modules is based on the basic grid dimension and can be up to five times the basic grid dimension. The panels are ideal for larger surfaces (max. 21.5 ft²). The use of longer modules can reduce the cost of installation by up to 80% compared to conventional systems available on the market.

For the lay-in system, the modules are placed on a T-shaped substructure.

Zehnder lay-in systems can be activated in two different ways:

- Activation by aluminium heat-conducting profiles and copper pipe meander.
- Activation by graphite sandwich with integrated copper pipe meander.

Further information:

Sound absorption	15
Technical data	21



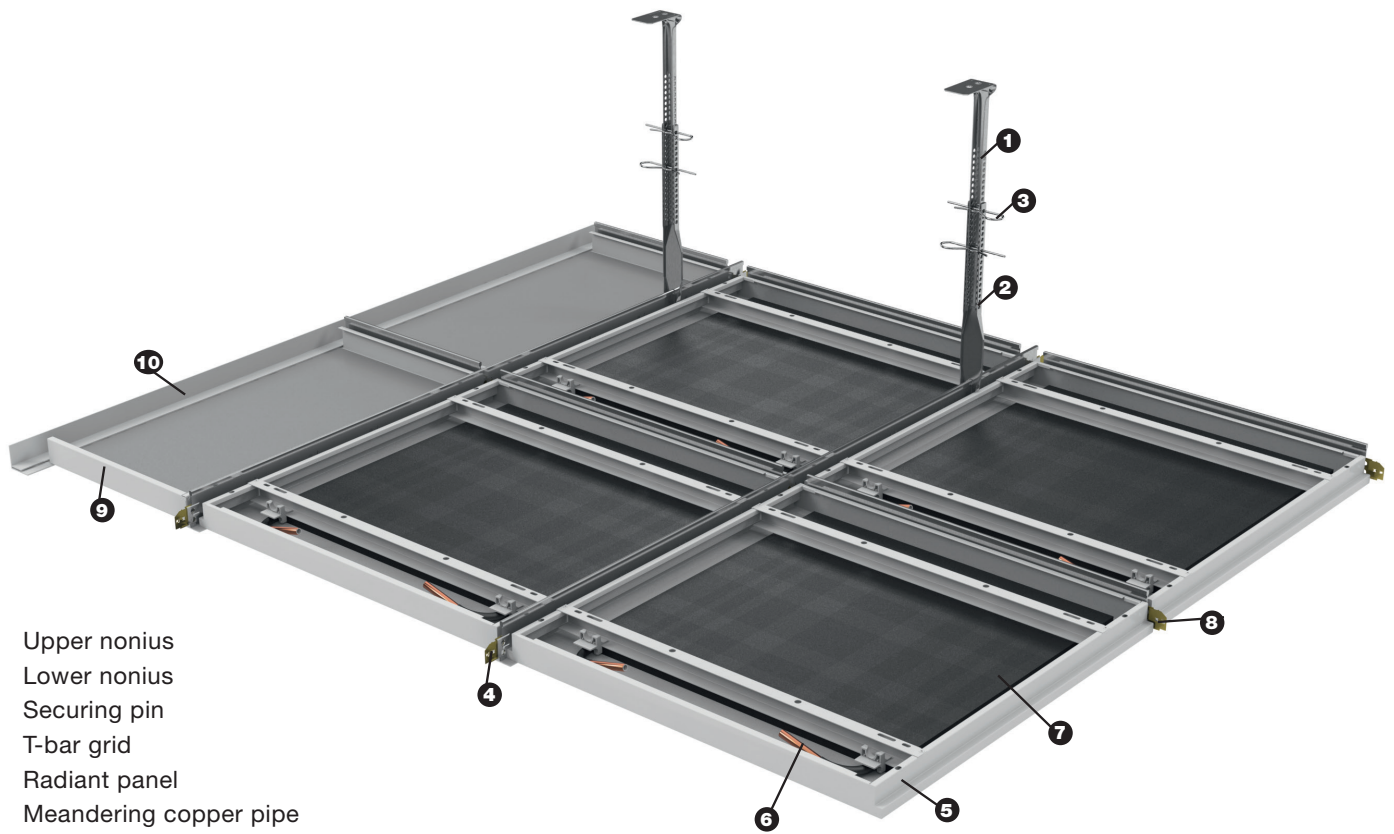

1. Upper nonius
2. Lower nonius
3. Securing pin
4. T-bar grid
5. Radiant panel
6. Meandering copper pipe
7. Graphite
8. T24 cross bars
9. Inactive panel
10. Wall bracket

Lay-in system	
Maximum panel length [in]	≤ 120
Maximum panel width [in]	≤ 24
Maximum recommended surface area / panel [ft ²]	20
Activation	Aluminium / graphite
Concealed substructure	-
Non-lift-out feature	▪
Inspection / modification possible	▪
Hinges down	▪
Suitable for subsequent modifications to room geometry	-
Sound absorption (perforated) $\alpha_s = 0.55-0.95$	▪
Allows installation of other features (lights, ventilation, etc.)	▪
Special colors	▪

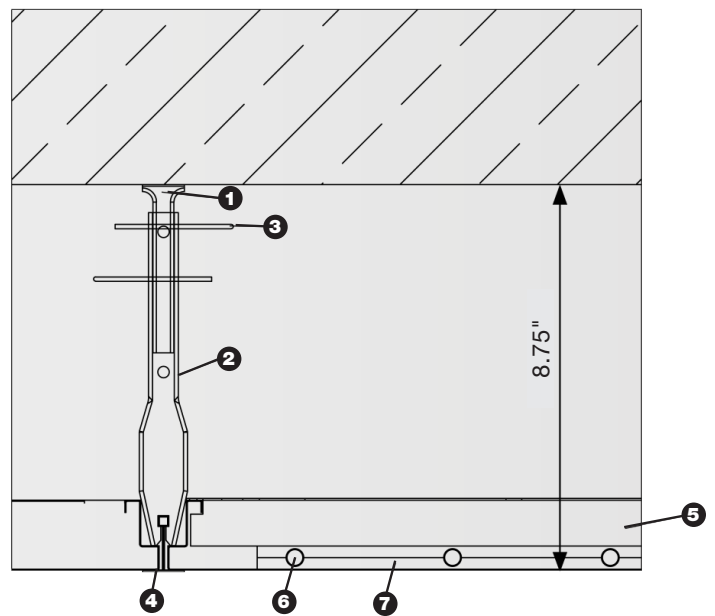

Ceiling sails

Zehnder ceiling sails are the energy-efficient, cost-effective solution for heating and cooling rooms. As they only require a short space under the structural ceiling, they are even ideal for properties with low room heights. The dimensions of Zehnder ceiling sails can be tailored to suit the individual requirements of any plan.

Our various installation kits for suspending and securing the ceiling sails integrate seamlessly into your overall ceiling layout.

Zehnder ceiling sails can be activated in two different ways:

- Activation by aluminium
- heat-conducting profiles and copper pipe meander.
- Activation by graphite sandwich with integrated copper pipe meander.

Further benefits of the ceiling sails:

- Fast and straightforward installation
- Very high sound absorption
- Available in numerous colors

Further information:

Sound absorption	15
Technical data	20



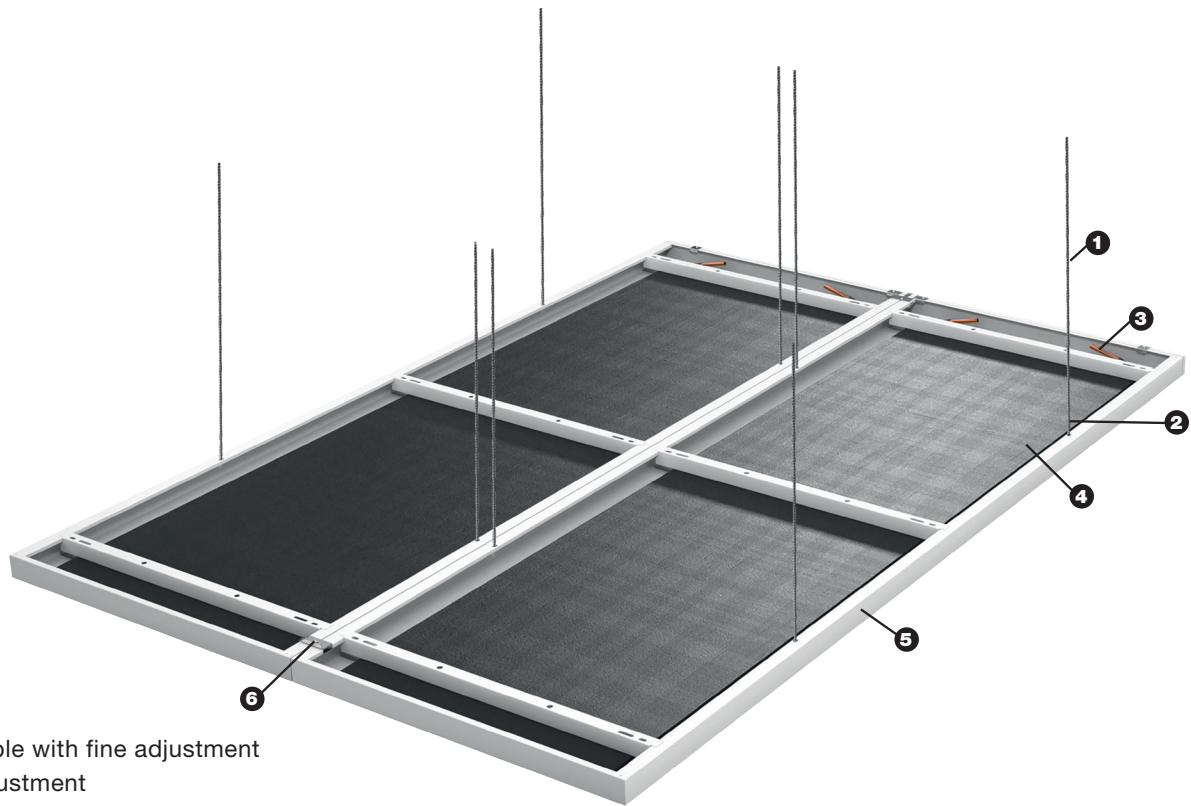

1. Wire cable with fine adjustment
2. Fine adjustment
3. Meandering copper pipe
4. Graphite
5. Radiant panel
6. Sail clip

Ceiling sails						
Activation	with graphite					with aluminum
Width [in]	23.62					11.81-47.24 ¹
Length [in]	23.62	47.24	70.87	94.49	118.11	19.7-118.11 ¹
Non-lift-out feature					▪	
Inspection / modification possible					▪	
Hinges down					▪	
Suitable for subsequent modification to room geometry					▪	
Sound absorption (perforated) $\alpha_s=0.55-0.95$					▪	
Allows installation of other features (lights, ventilation, etc.)					▪	
Special colors					▪	

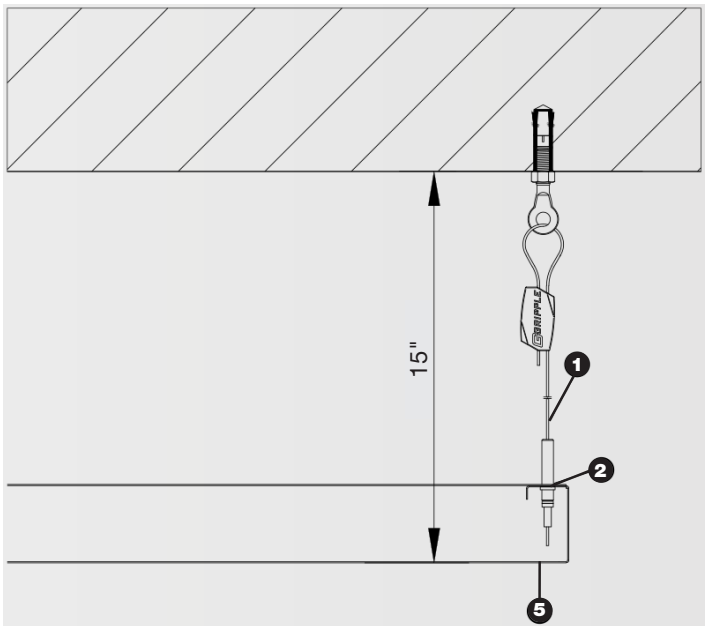

¹ The length and width are inter-dependent

Wall connections

A variety of wall connections can be used to match the appearance of closed ceiling systems to the room geometry.

For example, an L-bracket that connects directly to the vertical wall (Fig. 1).

The graded-edge angle that distinguishes the cooling ceiling from the wall is an ideal way to obtain the impression of a shadow gap at the wall (Fig. 2+3).

A further advantage of this wall bracket is the F-lip in the profile (Fig. 2+4). The cut edges of the ceiling panels are inserted into the lip here to prevent lifting or curving of the module.

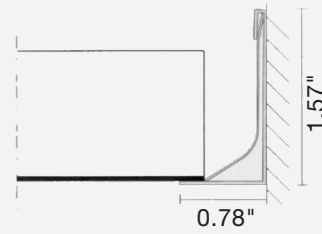

Edge angle for inactive panels cut on site (Fig. 1)

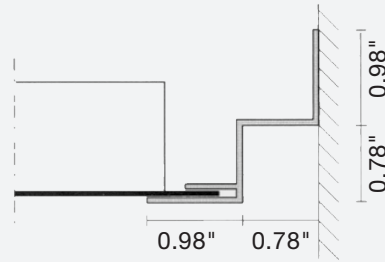

Graded-edge angle with F-lip for inactive panels cut on site (Fig. 2)



Graded-edge angle for installed inactive panels (Fig. 3)



Edge angle with F-lip for inactive panels cut on site (Fig. 4)



Edge angle for installed inactive panels (Fig. 5)



Surfaces and colors

Zehnder heating and cooling ceiling modules are available with the option of a smooth or perforated surface. The surface is coated with a high-quality powder coat finish. Zehnder ceiling modules are available in the standard color similar to RAL 9016.

Further colors on request.



Perforation

The perforation in the Zehnder heating and cooling ceiling modules also has a significant influence on the absorption characteristics.

Further perforation types are available on request.

Zehnder Alumline:

Hole diameter	0.059"
Open cross section	22%

Zehnder Carboline:

Hole diameter	0.082"
Open cross section	25%

Sound absorption

Zehnder heating and cooling ceiling systems can be used for sound absorption: The sound waves are absorbed by the fleece at the back and by the inserted insulation material. This results in a significant reduction

of the noise level and a reduction in the reverberation time (e.g. in open-plan offices, call centres and schools). Please contact us if you require detailed information on calculating the acoustics.

Ceiling sail with insulation

Activation by a heat-conducting profile made of aluminum

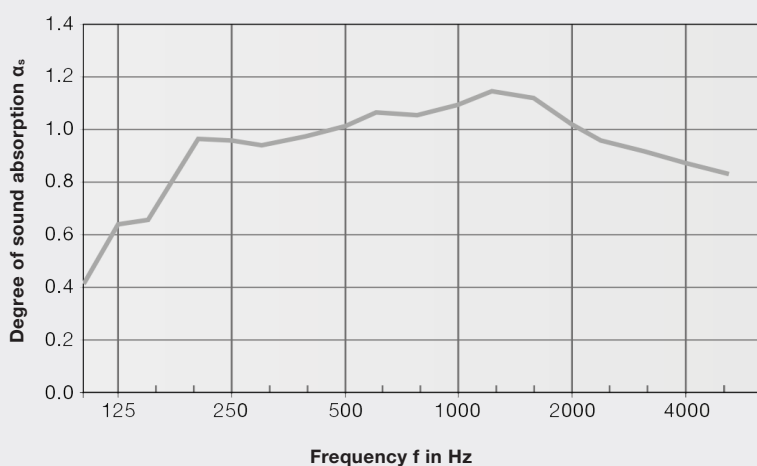

Description:	Aluminum-activated ceiling sail with insulation
Perforation:	RD-L30
Hole diameter:	0.059"
Open cross section:	22%
Non-perforated edge:	~0.39"
Insulation:	Ultra sound absorbing insulation, d = 0.98"
Construction depth:	15.74" (suspension height)

Closed ceiling with insulation

Activation by a heat-conducting profile made of aluminum

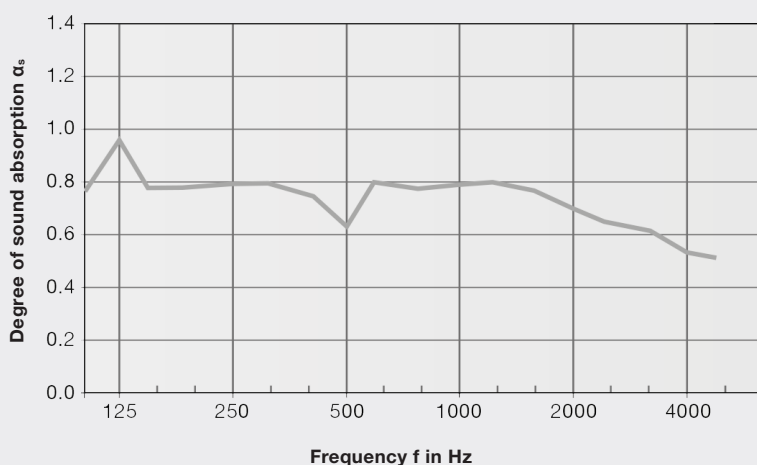

Description:	Aluminum-activated closed ceiling with insulation
Perforation:	RD-L30
Hole diameter:	0.059"
Open cross section:	22%
Non-perforated edge:	~0.39"
Insulation:	Ultra sound absorbing insulation, d = 0.98"
Construction depth:	15.74" (suspension height)

Graphite activation

Zehnder Carboline:

The ideal properties of the expanded natural graphite material, which is excellent at distributing heat quickly and evenly throughout the room, combine high thermal conductivity with minimal weight.

Zehnder Carboline

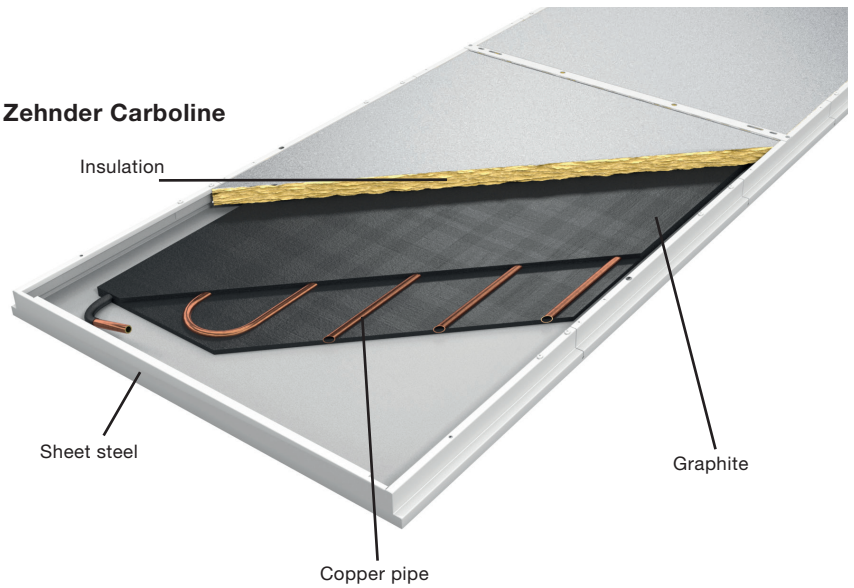

The thermography shows the comparison between Zehnder Carboline (radiant panel system on left) and a standard panel, both exposed to the same flow temperature and mass flow. Zehnder Carboline exhibits a higher surface temperature.

Θ = average surface temperature

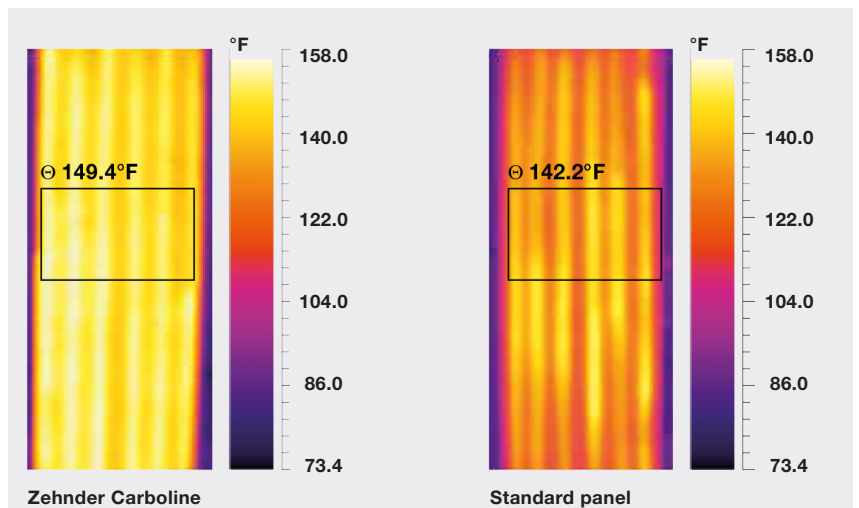

Further benefits:

- Expanded natural graphite guarantees an even temperature distribution
- Extremely short system response time when the temperature changes
- Ideal control comfort leads to high energy savings
- Energy savings due to the higher surface temperature

Temperature variance across the panel width

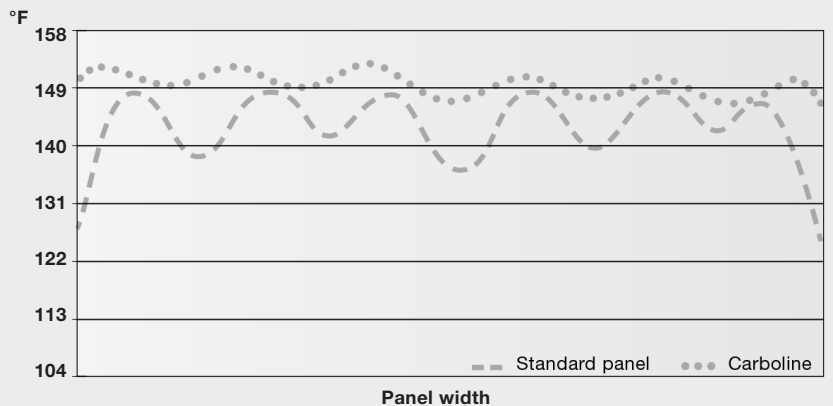

Aluminum activation

Zehnder Alumline:

The special D-shape of the copper pipe increases the surface area for thermal transfer to the aluminium heat-conducting profile and to the sheet steel.

In this way, the method of transfer is utilized most effectively.

Zehnder Alumline

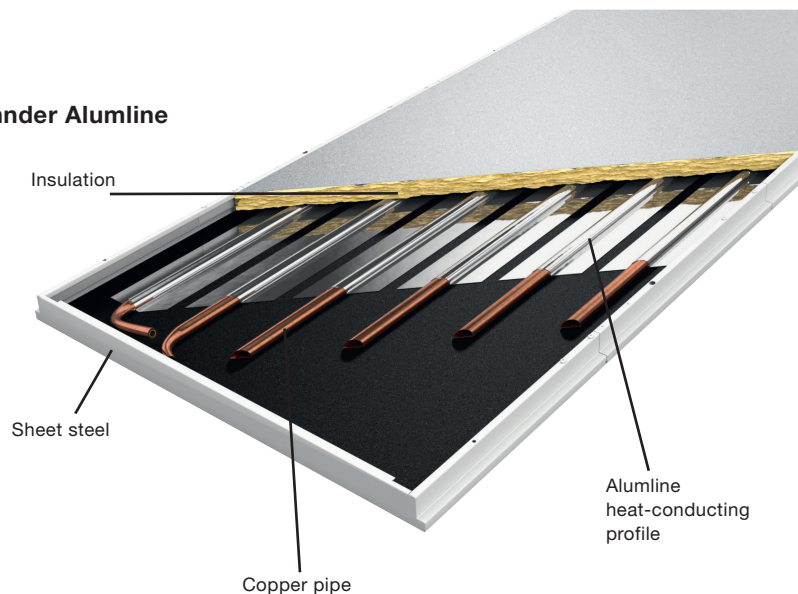

The thermograph shows that the D-pipe produces a more even and more pronounced thermal transfer than a conventional round tube. This is achieved by fully embedding the pipe, and on account of the large contact area of the pipe on the heating and cooling module. Energy savings are possible due to the higher surface temperature at the same flow temperature and mass flow.

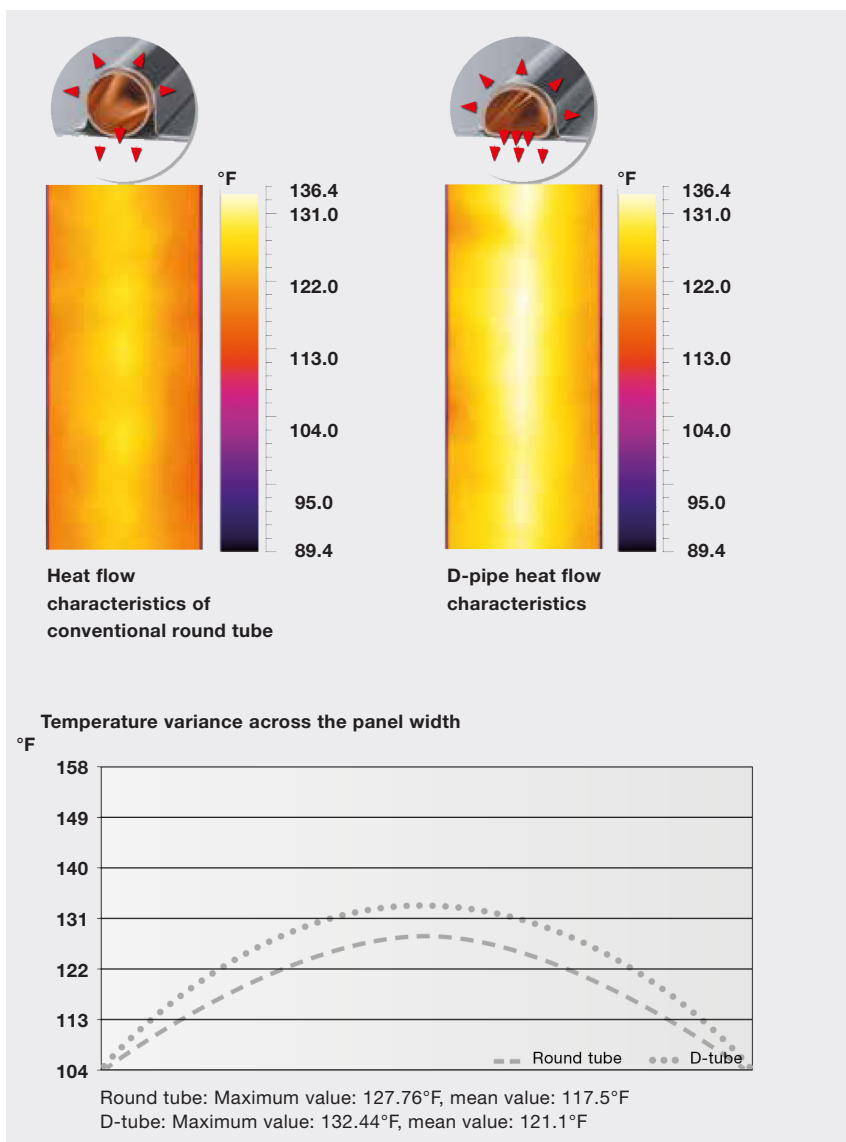

Further benefits:

- Efficient thermal transfer leads to high energy savings
- Low heating and flow temperatures
- Optimum control comfort
- Energy savings due to the higher surface temperature

Connection Options

For Zehnder heating and cooling ceiling systems, both connection pipes are located on the same end. This enables an installation friendly and quick connection of the radiant panel systems.

Additional connections available upon request.

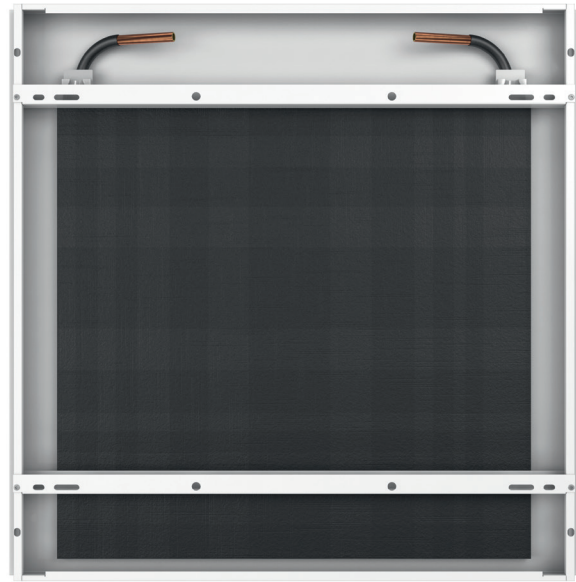

Connector technology

Special connector hoses are used to connect several individual elements to each other; they are connected directly to the pipes with no need for additional tooling.

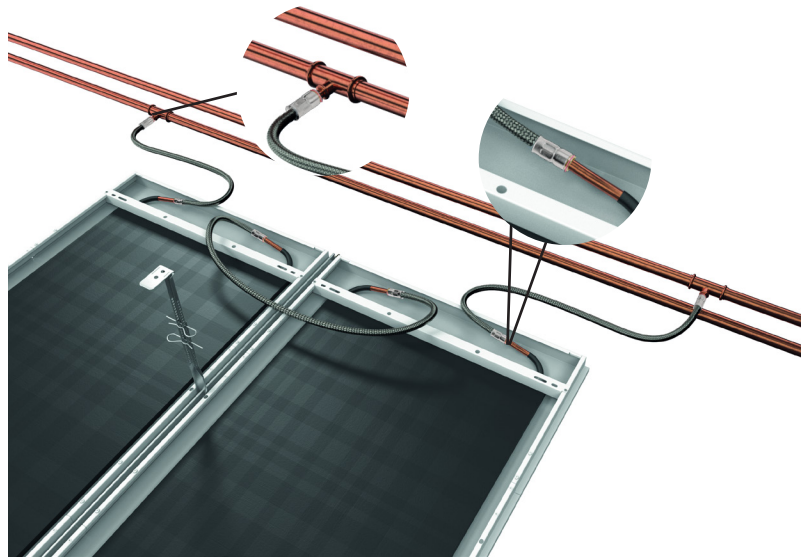

Special solutions

Ceiling cut-outs can be integrated into the panel elements of Zehnder heating and cooling ceiling systems as required. Ideal for offices or meeting rooms, ceiling recesses are possible, e.g. for air outlets, projector brackets, loudspeakers, fire alarms or lighting. Zehnder produces the required ceiling cut-outs precisely to the customer's specifications.

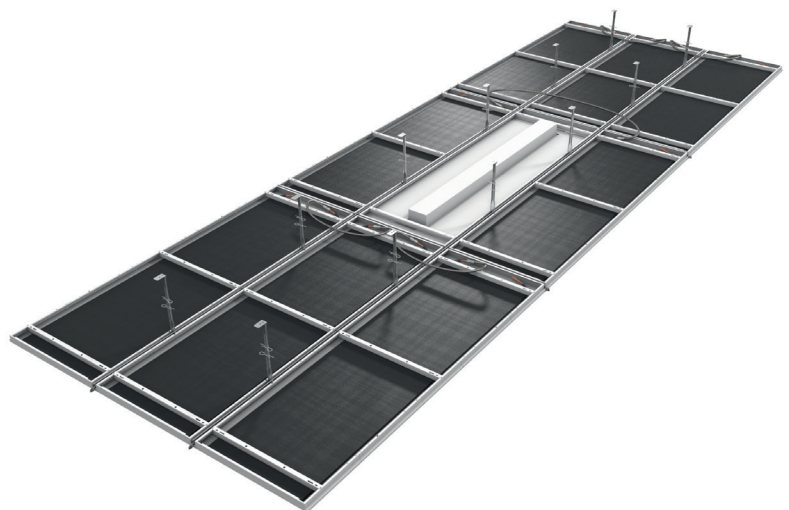
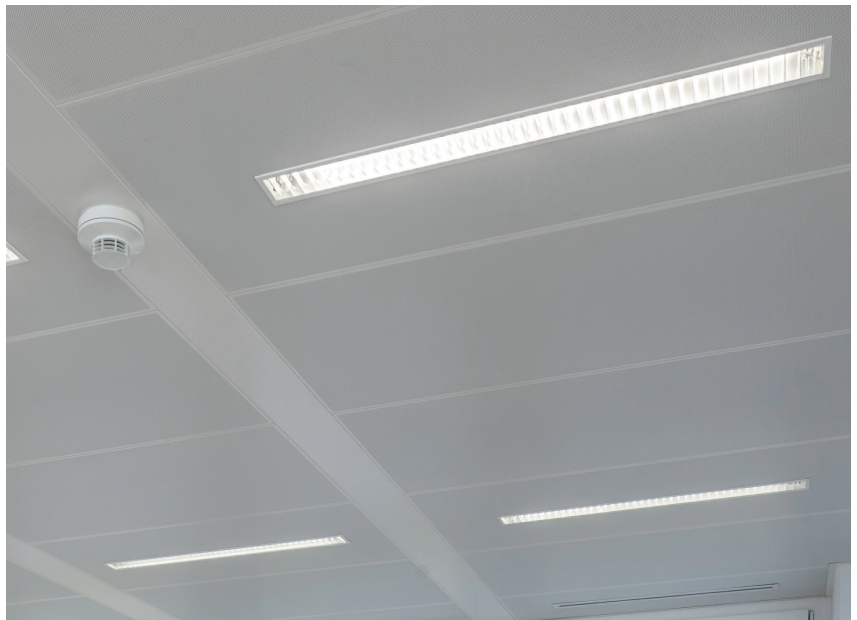

Technical data

Ceiling sails

System	Unit of measurement	Ceiling sails					
Activation	-	Graphite					Aluminium
Length	in	23.62	47.24	70.87	94.49	118.11	19.69 - 118.11 ¹
Width	in	23.62					11.81-47.24 ¹
Max. recommended surface area / panel ¹	ft ²	19.4					19.4
Panel material	-	Galvanized sheet steel					
Number of suspension points per module	Piece	4	4	4	4	6	4-6
Number of parallel pipes	Piece	6					Variable
Pipe material / dimension	- / in	Copper pipe / 0.5 (.62500)					D copper pipe / 0.5 (.62500)
Tube spacing	in	3.54					Variable
Empty weight without water, with insulation	lb	10.52	18.89	27.95	26.31	45.37	Depending on version, on request
Operating weight with water, with insulation	lb	10.98	19.89	29.45	38.31	47.90	Depending on version, on request
Max. operating temperature	°F	181					181
Max. operating pressure	psi	87					
Non-lift-out feature	-	■					
Inspection / modification possible	-	■					
Hinges down	-	■					
Suitable for subsequent modifications to room geometry	-	■					
Sound absorption (perforated) $\alpha_s= 0.55-0.95$	-	■					
Allows installation of other features (lights, ventilation, etc.)	-	■					
Special colors	-	■					

¹ The length and width are inter-dependent.

Technical data

Closed ceiling systems

System	Unit of measurement	C-Channel system	Clip-in system	Hook-on system	Lay-in system
Maximum panel length	in	78.74	78.74	78.74	118.11
Maximum panel width	in	51.18	47.24	51.18	23.62
Max. recommended surface area / panel	ft ²	16.14	8.61	18.29	21.53
Panel material	-	Galvanized sheet steel			
Pipe material / dimension	- / in	Copper pipe / 0.5 (.62500)			
Tube spacing	in	Min. 3.54			
Weight	lb	Depending on version, on request			
Max. operating temperature for activation with graphite	°F	181			
Max. operating temperature for activation with aluminium	°F	181			
Max. operating pressure	psi	87			
Activation	-	Aluminium ²	Aluminium ²	Aluminium ²	Aluminium / graphite
Concealed substructure	-	-	■	■	-
Force-fit connection	-	■	■	-	-
Non-lift-out feature	-	-	■	■	■
Inspection / modification possible	-	■	■	■	■
Hinges down	-	■	■	■	■
Suitable for subsequent modifications to room geometry	-	■	■	■	■
Sound absorption (perforated) $\alpha_s = 0.55-0.95$	-	■	■	■	■
Allows installation of other features (lights, ventilation, etc.)	-	■	-	-	-
Special colors	-	■	■	■	■

¹ The pipe dimension is 0.39" for the version with graphite.

² Further activation options on request.

Applications

Public buildings

The heating and cooling ceilings also integrate as an architectural design element for modern, suspended ceiling light fittings, for example. Generous, bright clarity of form and structure – an inviting atmosphere where customers will feel comfortable.



Schools

The generous foyer exhibits clarity of design, is modern and has an open layout. The heating and cooling ceiling systems also integrate ideally into the design concept. Besides visual aspects, performance features such as energy efficiency, costs and reliability are important considerations in open rooms.



Applications

Office buildings

Comfortable indoor climate in the meeting room. Besides the demand for cost-effective heating and cooling, the aim was to provide an aesthetic solution for the heat distribution system, particularly in conference rooms. The lighting and air outlets also harmonize with the cooling ceiling.



University

Architects use color and light as a means of visual enhancement here. The harmonious integration of the heating and cooling ceiling system underlines the special atmosphere. Design demands blend with a comfortable indoor climate for top performance in any season.



The one-stop custom solution

Zehnder's new heating and cooling ceiling systems are customer-friendly complete solutions for heating and cooling commercial buildings.

The service package covers the full process from consulting and planning to production, installation and commissioning. You will have one Zehnder contact throughout the whole

project - your guarantee for planning reliability, cost transparency and a smooth, highly efficient construction process.

1. Advice

Our technical contacts ensure that you receive individual advice and comprehensive support.



2. Planning

Engineers, technicians and drafters in our in-house planning department design top-grade heating and cooling ceilings tailored down to the last detail.

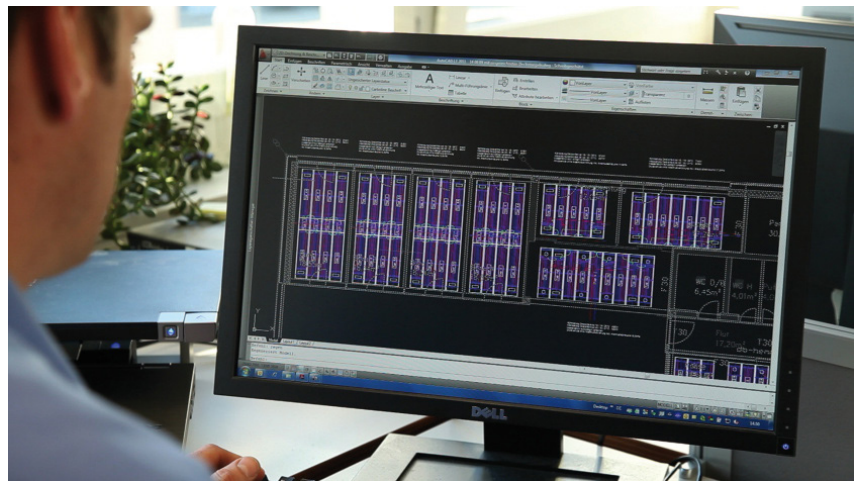

3. Production

We produce environmentally-friendly, top-quality customized heating and cooling ceilings in a high-tech production plant.





Warranty

Zehnder Rittling guarantees its products to be free from defects in material and workmanship for a period of five years from date of shipment from our factory.

Should there be any defects in the good(s), the purchaser should promptly notify Zehnder Rittling. Upon receipt of written consent from Zehnder Rittling, the purchaser shall return the defective good(s) to the factory for inspection with freight prepaid. If inspection shows the goods to be defective, Zehnder Rittling will at its discretion repair or replace the said item(s). Defects arising from damage due to shipment, improper installation, negligence or misuse by others are not covered by this warranty.

This warranty is extended only to the original purchaser from Zehnder Rittling.

