

ENCLOSURES ARE AVAILABLE IN
1 FT. TO 8 FT. LENGTHS
IN 6 IN. INCREMENTS

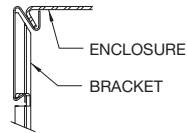

SNAP MOUNTING
CHANNEL DETAIL

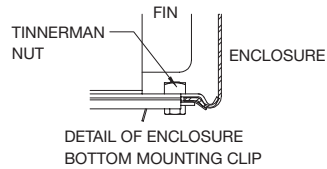

SECTION "X - X"
INTERNAL JOGGLE - JOINER

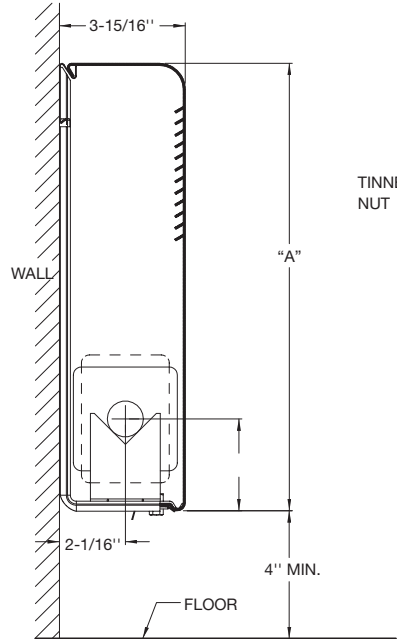

* CENTERLINES ARE BASED ON 1" COPPER TUBE

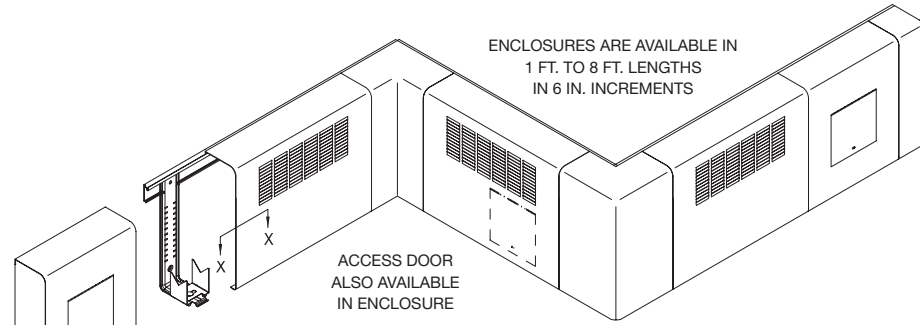

ACCESS DOOR
ALSO AVAILABLE
IN ENCLOSURE

ACCESSORIES

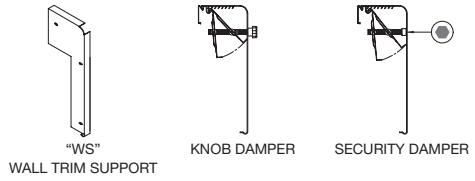
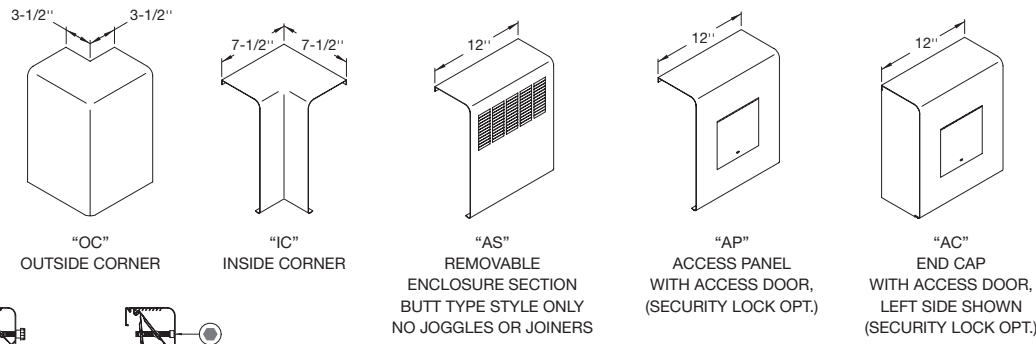
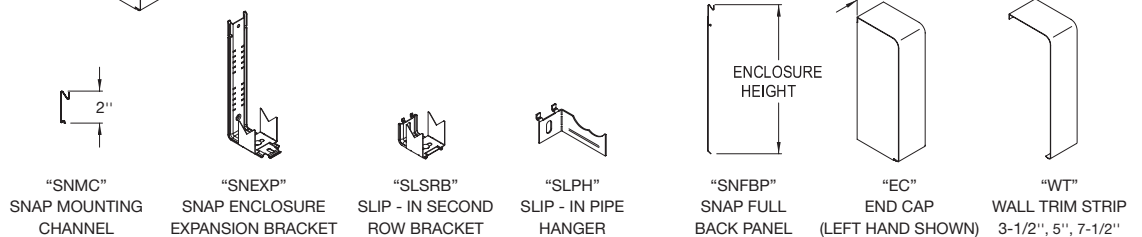

NOTE:
1) ALL ACCESSORIES OVERLAP
(EXCEPT AS NOTED)
2) BUTT TYPE (INTERLOCKING) STYLE OPTIONAL
(EXCEPT AS NOTED)



| MODEL | PIPE SIZE | | FIN SIZE | A |
|-------|------------|------------------|-----------------|-----|
| | STEEL | COPPER | | |
| FF3 | N/A | 3/4", 1", 1-1/4" | 2-3/4" x 4" | 8" |
| | | | | 11" |
| | 1", 1-1/4" | 3/4", 1", 1-1/4" | 3-1/4" x 3-1/4" | 14" |

| | | |
|----------------------|--|--|
| CONTRACTOR _____ | ELEMENT _____ | ZEHNDER RITTLING 100 RITTLING BLVD. • BUFFALO, NY USA 14220 |
| ARCHITECT _____ | RATING _____ BTU _____ A.W.T. _____ E.A.T. _____ | JOB: _____ |
| ENGINEER _____ | BACKPLATE _____ FULL _____ PARTIAL _____ | ENCLOSURE MODEL: FF3 |
| REPRESENTATIVE _____ | ENCL. GAUGE _____ MATERIAL _____ | DATE: January 2011 |
| LOCATION _____ | COLOR _____ DAMPER _____ | DWG.NO.: FF3 |