

Transformer - Voltage to Wire Color Chart

Voltage	Wire Color
120	White
208	Red
240	Orange
277	Brown
Common	Black

CONNECT SPECIFIED SUPPLY VOLTAGE PER WIRE COLOR LEAD ON TRANSFORMER TO L1 CONNECTOR CAP ALL OTHER WIRE COLORS LEADS

NOTE:
MOTOR #2 ONLY PROVIDED ON SIZES 08, 10 & 12

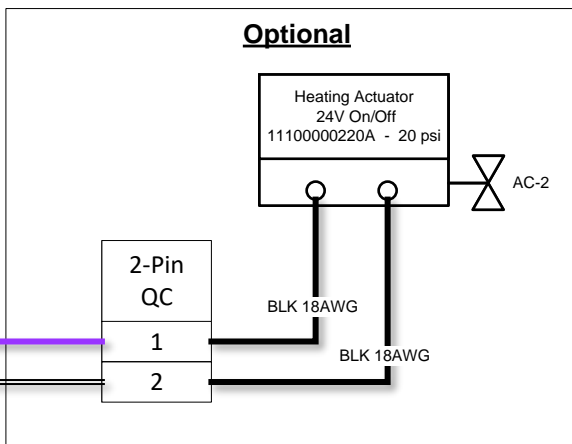
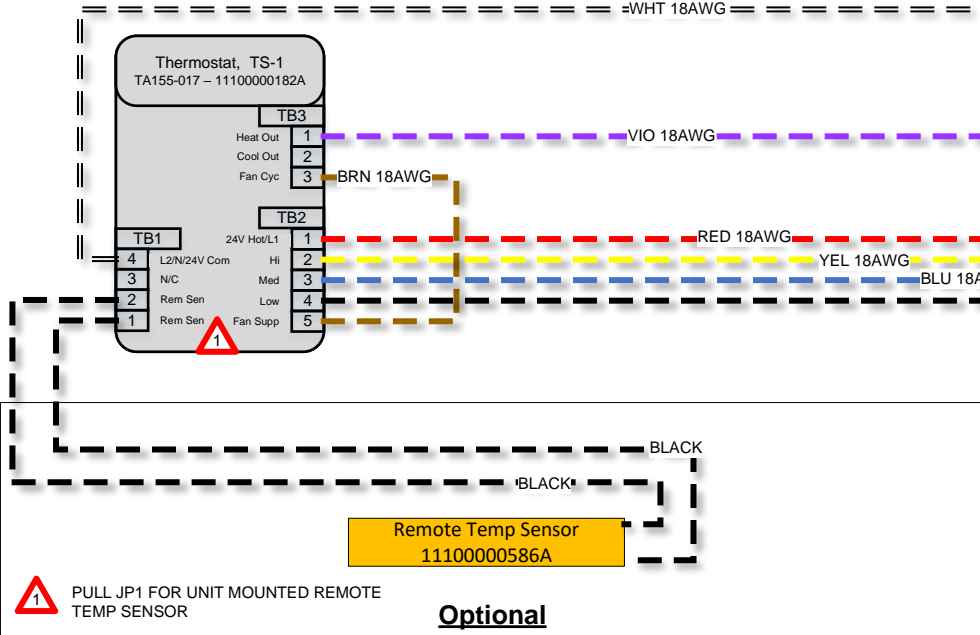

LEGEND

- FIELD WIRED
- FACTORY WIRED
- FIELD CONNECTION
- FACT. CONNECTION
- + FACTORY WIRE - NOT CONNECTED
- WIRE TERMINATION

- NOTES:**
- COMPLETE THE WIRING IN ACCORDANCE WITH NATIONAL AND LOCAL CODES.
 - USE SOLID COPPER SUPPLY WIRES.
 - CONNECTOR LABEL MATCHES SUB-PANEL.
 - ONLY USE DIRECT REPLACEMENT COMPONENTS.
 - FIELD INSTALLED REMOTE TEMPERATURE SENSOR: WIRE TO THERMOSTAT TB1 TERMINALS 1 AND 2.
 - CONTROLLER SHIPPED LOOSE IF WALL MOUNTED.
 - CONTROL VALVE IS SHIPPED LOOSE.

CAUTION: NOT FOLLOWING PROPER WIRING PROCEDURE CAN CAUSE INJURY OR DEATH.

	NAME	DATE
DRAWN BY	DH	12/06/24
MECH APPR.	--	--
ELEC APPR.	--	--
ENG APPR.	--	--
MFG APPR.	--	--

zehnder Rittling
BUFFALO, NEW YORK

DESCRIPTION
2V4T ECM 3SPD 277/60/1
WMC TEMP CUH DRAWING

SIZE	PART NO.	REV.
B	11D00035961A	A

SHEET 1 OF 1

PROPRIETARY AND CONFIDENTIAL
THE INFORMATION CONTAINED IN THIS DRAWING IS THE SOLE PROPERTY OF ZEHNDER. ANY REPRODUCTION IN PART OR AS A WHOLE WITHOUT THE WRITTEN PERMISSION OF ZEHNDER IS PROHIBITED.