

**NOTE:**  
MOTOR #2 ONLY  
PROVIDED ON  
SIZES 08, 10 & 12

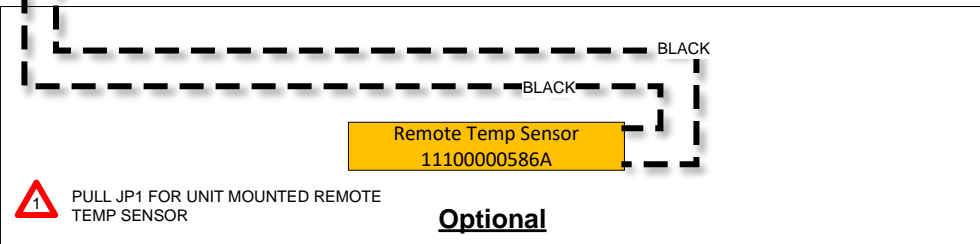
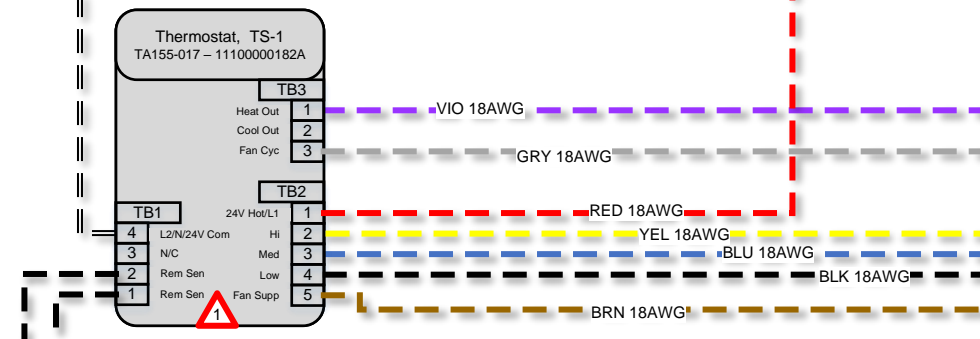
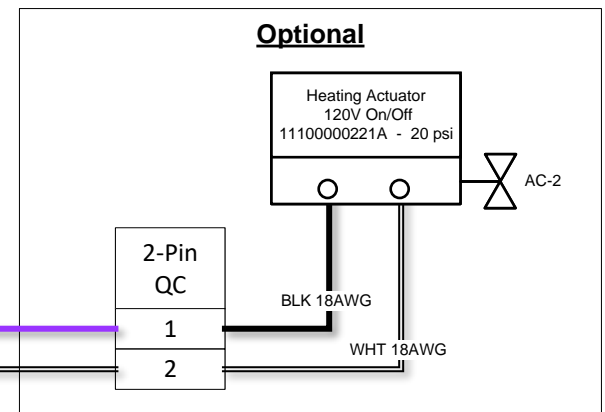

**LEGEND**

- FIELD WIRED
- FACTORY WIRED
- FIELD CONNECTION
- FACT. CONNECTION
- + FACTORY WIRE – NOT CONNECTED
- WIRE TERMINATION

- NOTES:**
- COMPLETE THE WIRING IN ACCORDANCE WITH NATIONAL AND LOCAL CODES.
  - USE SOLID COPPER SUPPLY WIRES.
  - CONNECTOR LABEL MATCHES SUB-PANEL.
  - ONLY USE DIRECT REPLACEMENT COMPONENTS.
  - FIELD INSTALLED REMOTE TEMPERATURE SENSOR: WIRE TO THERMOSTAT TB1 TERMINALS 1 AND 2.
  - CONTROLLER SHIPPED LOOSE IF WALL MOUNTED.
  - CONTROL VALVE IS SHIPPED LOOSE.

**CAUTION:** NOT FOLLOWING  
PROPER WIRING PROCEDURE  
CAN CAUSE INJURY OR DEATH.

	NAME	DATE
DRAWN BY	DH	10/29/24
MECH APPR.	--	--
ELEC APPR.	--	--
ENG APPR.	--	--
MFG APPR.	--	--

**zehnder** Rittling  
BUFFALO, NEW YORK

DESCRIPTION  
2V0T PSC 3SPD 120/60/1  
WMC TEMP CUH DRAWING

SIZE <b>B</b>	PART NO. <b>11D00035930A</b>	REV. <b>A</b>
------------------	---------------------------------	------------------

SHEET 1 OF 1

**PROPRIETARY AND CONFIDENTIAL**  
THE INFORMATION CONTAINED IN THIS  
DRAWING IS THE SOLE PROPERTY OF  
ZEHNDER. ANY REPRODUCTION IN PART  
OR AS A WHOLE WITHOUT THE WRITTEN  
PERMISSION OF ZEHNDER IS PROHIBITED.