

Rittling Econo-Line Enclosures

Catalog





Zehnder decorative radiators



Heating and cooling ceiling systems

zehnder

always the
best climate

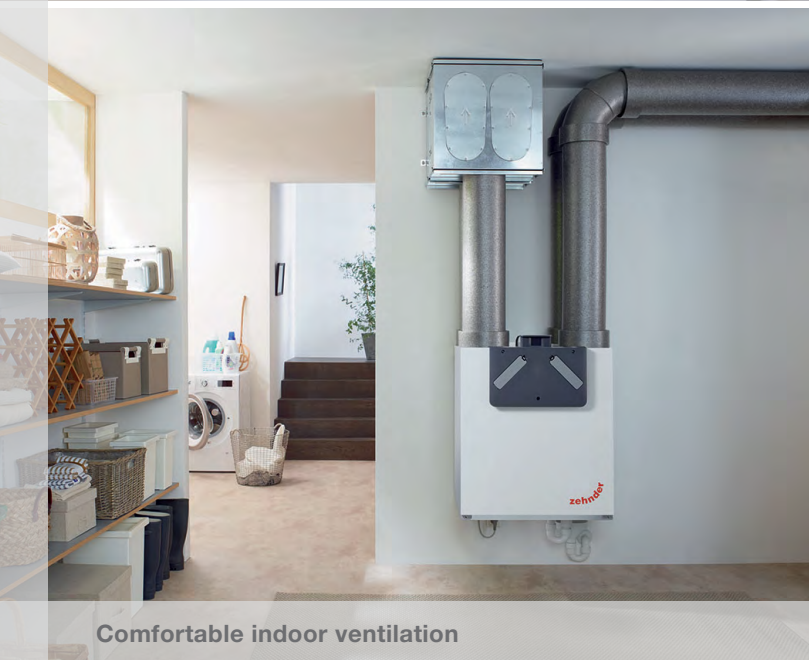

Comfortable indoor ventilation



Clean air solutions

Always the best climate for

IMPROVED QUALITY OF LIFE

*With Zehnder, you will find the perfect
climate for any space.*

www.zehnder-systems.com



Custom-building innovative hydronic systems for commerce, industry and institutions since 1946

Zehnder Rittling long ago coined the phrase “Reinventing Finned Tube” to describe its commitment to design innovation and its unlimited custom engineering capability. For decades, Zehnder Rittling's constantly expanding inventory and proven ability to control costs without compromising the highest quality standards in manufacturing have made the name synonymous with image, performance, reliability, price, delivery and service.

Zehnder Rittling's diversity and flexibility have freed architects from the constraints of designing around limited catalog selections of standard elements and enclosure configurations. Today Zehnder Rittling engineers can draw on, or modify, any of 42 different hydronic heating elements and 150 standard enclosure models to build any system an architect can draw to tolerances of less than 0.03125 inch, at an exceptionally competitive cost.

For the architects of the future, Zehnder Rittling will continue to advance finned tube technology in still more new directions and develop ever more efficient, cost-effective hydronic heat transfer systems.

Over sixty-five years of quality, innovation and service... and we're just getting warmed up.

Overview	2
Models	3
STEL Performance ratings	4
ETO Performance ratings	5
EXO Performance ratings	9
Dimensions and data	13
Accessories	14
Design data	16
Mechanical specifications	18
Special applications	19
Warranty	20

STEL enclosures

Features

Econo-Line slope-top baseboard enclosures from Zehnder Rittling are an excellent choice for light commercial applications such as banks, offices, hospitals and housing renovations.

Econo-Line is designed to provide high heat output through a sloped louvered gridded. The enclosures can accommodate nine types of Zehnder Rittling copper/aluminum finned tube with nominal diameters of 3/4, 1 or 1-1/4 inches, fins measuring 2-3/4 by 4 inches and fin spacing of 32, 40 or 48 per foot.

Enclosure sections are available in 15 lengths from 1 through 8 feet in 6 inch increments for a custom fit.

Enclosure:

- 14, 16, 18-gauge primed coated
- 1' to 8' lengths in 6" increments
- Powder coated finish, available in decorator colors)
- Stainless steel available

Copper/Aluminum Element

- Tube: 3/4", 1" or 1-1/4"
 - Fin: 2-3/4" x 4"
 - 1' to 12' lengths in 6" increments
- (See our Element catalog for more information).

Mounting:

- 20 gauge full back panel, prime coated
- Urethane gasket for air seal available
- 4' or 8' lengths available

Hangers:

- 16 gauge galvanized.
- Fin clip (slider) 0.03" galvanized steel will accommodate 2-1/2 inch linear expansion for quiet operation.

Damper: (optional)

- Durable knob
- Security tamper proof

ETO and EXO enclosures

Features

For use with one, two, or three vertical rows of wall mounted finned tube. ETO (top-louvered outlet) and EXO (expanded metal) enclosures slip securely over one, two or three vertical rows of wall-mounted finned tube. The tube is set in place in Zehnder Rittling's universal, cradle-type expansion brackets and lagged to the wall at the desired height. These enclosures are used where protection of the element is the only concern, the enclosure rests directly on the element.

The EXO enclosure allows the open output similar to bare element applications, while preventing direct contact.

The ETO enclosure provides the appearance of an enclosure while protecting the element from contact.

Both enclosures can be removed without tools.

Enclosure:

- 14, 16, 18-gauge primed coated
- 1' to 8' lengths in 6" increments
- Powder coated finish, available in decorator colors)
- Stainless steel available

Copper/Aluminum Element

- Tube: 3/4", 1" or 1-1/4"
- Fin: 3-1/4" x 3-1/4" or 4-1/4" x 4-1/4"
- 1' to 12' lengths in 6" increments

Steel Element

- Tube: 1", 1-1/4" or 2"
 - Fin: 3-1/4" x 3-1/4" or 4-1/4" x 4-1/4"
 - 1' to 12' lengths in 6" increments
- (See our Finned Tube catalog for more information).

Hangers:

- Second row bracket, wall mounted.

Enclosure models

STEL

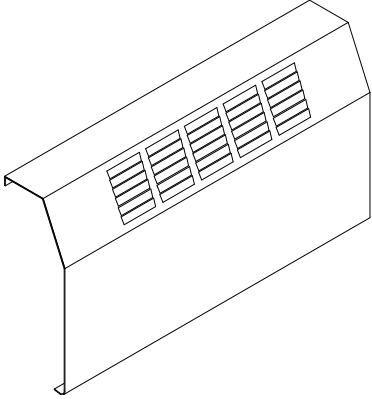

STEL:
Sloped louvered outlet, open inlet

[Performance data, 4](#)
[Dimensional Data, 13](#)

ETO

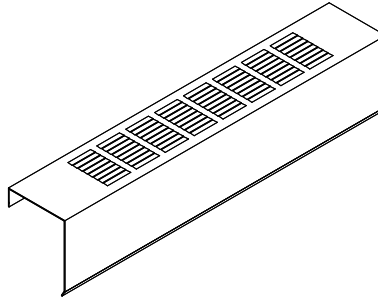

ETO:
Top louvered outlet, 1 row high

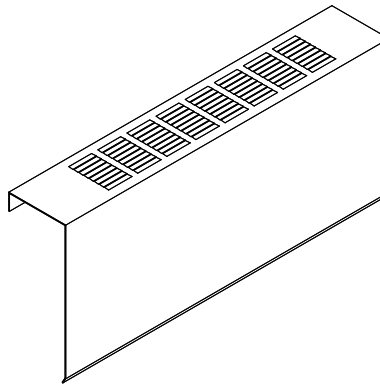

ETO:
Top louvered outlet, 2 rows high

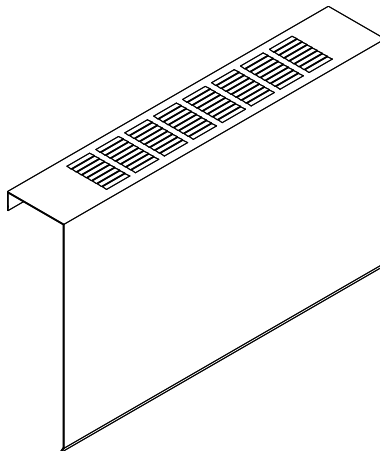

ETO:
Top louvered outlet, 3 rows high

[Performance data, 5-8](#)
[Dimensional Data, 13](#)

EXO

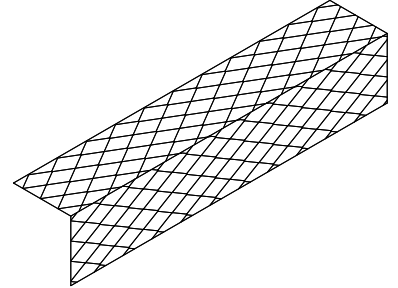

EXO:
Expanded metal, 1 row high

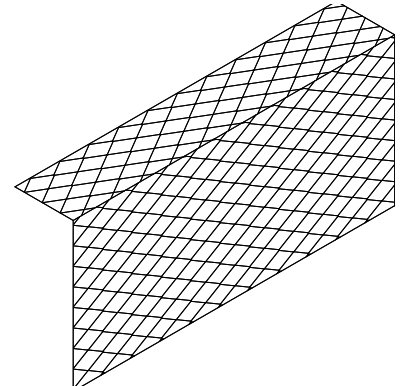

EXO:
Expanded metal, 2 rows high

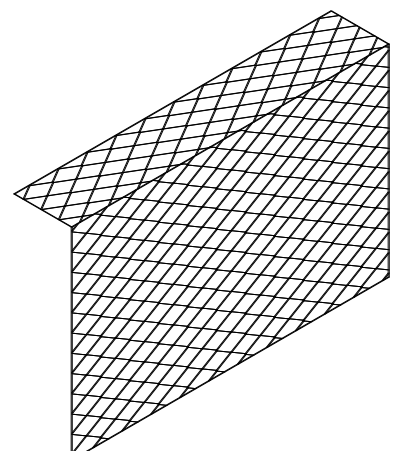

EXO:
Expanded metal, 3 rows high

[Performance data, 9-12](#)
[Dimensional Data, 13](#)

Performance ratings

Model STEL

In BTU/hr per active (finned) lineal foot of tube at entering air temperature of 65°F

Element	EDR* (ft ² / ft)	Steam heat	Hot water heat									
		215°F Factor of 1.00	240°F Factor of 1.25	230°F Factor of 1.14	220°F Factor of 1.05	210°F Factor of 0.95	200°F Factor of 0.86	190°F Factor of 0.78	180°F Factor of 0.69	170°F Factor of 0.61	160°F Factor of 0.53	
Copper element												
¾" Dia. copper	¾C-2¾ X 4-32	4.40	1060	1325	1205	1115	1000	915	830	730	650	560
	¾C-2¾ X 4-40	4.80	1150	1435	1310	1210	1100	990	900	790	700	610
	¾C-2¾ X 4-48	5.20	1240	1550	1410	1300	1180	1070	970	850	760	660
1" Dia. copper	1C-2¾ X 4-32	4.30	1030	1280	1175	1080	980	890	800	710	630	550
	1C-2¾ X 4-40	4.70	1130	1400	1285	1190	1075	975	880	780	690	600
	1C-2¾ X 4-48	5.10	1220	1525	1390	1280	1160	1050	950	840	740	650
1¼" Dia. copper	1¼C-2¾ X 4-32	4.10	980	1225	1115	1030	930	845	760	680	600	520
	1¼C-2¾ X 4-40	4.60	1100	1375	1255	1155	1050	950	840	760	670	580
	1¼C-2¾ X 4-48	5.00	1200	1500	1370	1260	1140	1040	920	830	730	640

*EDR - Equivalent Direct Radiation area (for steam heat) per active (finned) lineal foot of tube.

Important Rating Information Performance ratings based on:

- Installation at height shown. (Lower heights are not recommended. For greater heights, refer to EZselect selection software.)
- Entering air temperature of 65°F. (For other temperatures, refer to EZselect selection software.)

- Steam at nominal 1 (actual 0.9) psig and 215°F. (For other conditions, refer to EZselect selection software.)
- Water average temperature (°F) shown and velocity of 3 fps or more. (For lower velocities, refer to EZselect selection software.)

Performance ratings

Model ETO

In BTU/hr per active (finned) lineal foot of tube at entering air temperature of 65°F

Element	Rows of element (on 6-inch centers)	Enclosure height (in inches)	Recommended minimum installed height (in inches)	EDR* (ft ² / ft)	Steam heat	Hot water heat				
					215°F factor of 1.00	190°F factor of 0.78	180°F factor of 0.69	170°F factor of 0.61	160°F factor of 0.53	
Steel element										
1" Dia. steel	1S-3¼ X 3¼-32	1	3-5/8	7-5/8	3.10	750	580	510	460	400
		2	9-5/8	13-5/8	5.20	1270	980	880	770	670
		3	15-5/8	19-5/8	6.30	1500	1190	1050	930	810
	1S-3¼ X 3¼-40	1	3-5/8	7-5/8	3.40	820	640	560	490	440
		2	9-5/8	13-5/8	5.70	1390	1080	960	850	730
		3	15-5/8	19-5/8	6.60	1590	1240	1090	970	840
	1S-3¼ X 3¼-48	1	3-5/8	7-5/8	3.70	890	690	610	540	470
		2	9-5/8	13-5/8	6.10	1470	1150	1010	900	780
		3	15-5/8	19-5/8	7.10	1710	1340	1180	1040	910
1" Dia. steel	1S-4¼ X 4¼-32	1	4-5/8	8-5/8	4.20	1000	780	690	610	530
		2	10-5/8	14-5/8	7.00	1690	1320	1160	1030	900
		3	16-5/8	20-5/8	8.00	1930	1500	1330	1170	1010
	1S-4¼ X 4¼-40	1	4-5/8	8-5/8	4.60	1100	860	760	670	580
		2	10-5/8	14-5/8	7.70	1860	1450	1280	1130	980
		3	16-5/8	20-5/8	8.40	2010	1570	1390	1230	1060
	1S-4¼ X 4¼-48	1	046	8.625	4.92	1131	880	780	690	600
		2	106	14.625	8.22	1891	1470	1300	1150	1000
		3	166	20.625	9.13	2100	1640	1450	1280	1110

*EDR - Equivalent Direct Radiation area (for steam heat) per active (finned) lineal foot of tube.

Important Rating Information Performance ratings based on:

- Installation at height shown. (Lower heights are not recommended. For greater heights, refer to EZselect selection software.)
- Entering air temperature of 65°F. (For other temperatures, refer to EZselect selection software.)

- Steam at nominal 1 (actual 0.9) psig and 215°F. (For other conditions, refer to EZselect selection software.)
- Water average temperature (°F) shown and velocity of 3 fps or more. (For lower velocities, refer to EZselect selection software.)

Performance ratings

Model ETO

In BTU/hr per active (finned) lineal foot of tube at entering air temperature of 65°F

Element	Rows of element (on 6-inch centers)	Enclosure height (in inches)	Recommend-ed minimum installed height (in inches)	EDR* (ft ² / ft)	Steam heat	Hot water heat				
					215°F factor of 1.00	190°F factor of 0.78	180°F factor of 0.69	170°F factor of 0.61	160°F factor of 0.53	
Steel element										
1/4" Dia. steel	1¼S-3¼ X 3¼-32	1	3-5/8	7-5/8	3.20	770	600	530	470	410
		2	9-5/8	13-5/8	5.40	1300	1010	900	790	690
		3	15-5/8	19-5/8	6.50	1560	1220	1080	950	830
	1¼S-3¼ X 3¼-40	1	3-5/8	7-5/8	3.50	840	660	580	510	450
		2	9-5/8	13-5/8	5.90	1420	1110	980	870	750
		3	15-5/8	19-5/8	6.80	1630	1270	1120	990	860
	1¼S-3¼ X 3¼-48	1	3-5/8	7-5/8	3.80	910	710	630	560	480
		2	9-5/8	13-5/8	6.30	1510	1180	1040	920	800
		3	15-5/8	19-5/8	7.30	1750	1370	1210	1070	930
1/4" Dia. steel	1¼S-4¼ X 4¼-32	1	4-5/8	8-5/8	4.30	1030	800	710	630	550
		2	10-5/8	14-5/8	7.20	1730	1350	1190	1060	920
		3	16-5/8	20-5/8	8.20	1970	1540	1360	1200	1040
	1¼S-4¼ X 4¼-40	1	4-5/8	8-5/8	4.70	1130	880	780	690	600
		2	10-5/8	14-5/8	7.90	1900	1480	1310	1160	1010
		3	16-5/8	20-5/8	8.60	2060	1610	1420	1260	1090
	1¼S-4¼ X 4¼-48	1	4-5/8	8-5/8	5.10	1220	950	840	740	650
		2	10-5/8	14-5/8	8.50	2040	1590	1410	1240	1080
		3	16-5/8	20-5/8	9.40	2260	1760	1560	1380	1200
2" Dia. steel	2S-4¼ X 4¼-32	1	4-5/8	8-5/8	4.40	1060	830	730	650	560
		2	10-5/8	14-5/8	7.30	1750	1370	1210	1070	930
		3	16-5/8	20-5/8	7.80	1870	1460	1290	1140	990
	2S-4¼ X 4¼-40	1	4-5/8	8-5/8	5.10	1220	950	840	740	650
		2	10-5/8	14-5/8	8.50	2040	1590	1410	1240	1080
		3	16-5/8	20-5/8	8.80	2110	1650	1460	1290	1120
	2S-4¼ X 4¼-48	1	4-5/8	8-5/8	6.00	1440	1120	900	880	760
		2	10-5/8	14-5/8	9.80	2350	1830	1620	1430	1250
		3	16-5/8	20-5/8	10.00	2400	1870	1660	1460	1270

*EDR - Equivalent Direct Radiation area (for steam heat) per active (finned) lineal foot of tube.

Important Rating Information Performance ratings based on:

- Installation at height shown. (Lower heights are not recommended. For greater heights, refer to EZselect selection software.)
- Entering air temperature of 65°F. (For other temperatures, refer to EZselect selection software.)

- Steam at nominal 1 (actual 0.9) psig and 215°F. (For other conditions, refer to EZselect selection software.)
- Water average temperature (°F) shown and velocity of 3 fps or more. (For lower velocities, refer to EZselect selection software.)

Performance ratings

Model ETO

In BTU/hr per active (finned) lineal foot of tube at entering air temperature of 65°F

Element	Rows of element (on 6-inch centers)	Enclosure height (in inches)	Recommend- ed minimum installed height (in inches)	EDR* (ft ² / ft)	Steam heat	Hot water heat				
					215°F factor of 1.00	190°F factor of 0.78	180°F factor of 0.69	170°F factor of 0.61	160°F factor of 0.53	
Copper/aluminum element										
¾" Dia. copper	¾C-3¼ X 3¼-32	1	3-5/8	7-5/8	3.70	900	700	630	550	470
		2	9-5/8	13-5/8	6.50	1570	1220	1080	950	830
		3	15-5/8	19-5/8	8.50	2060	1610	1410	1250	1090
	¾C-3¼ X 3¼-40	1	3-5/8	7-5/8	4.00	970	760	670	600	520
		2	9-5/8	13-5/8	6.90	1660	1290	1140	950	870
		3	15-5/8	19-5/8	8.00	1930	1500	1330	1180	1030
	¾C-3¼ X 3¼-48	1	3-5/8	7-5/8	4.30	1050	810	720	640	560
		2	9-5/8	13-5/8	7.30	1730	1350	1190	1060	910
		3	15-5/8	19-5/8	8.30	1950	1530	1340	1190	1040
¾" Dia. copper	¾C-4¼ X 4¼-32	1	4-5/8	8-5/8	5.50	1310	1030	900	800	690
		2	10-5/8	14-5/8	9.20	2220	1730	1530	1350	1170
		3	16-5/8	20-5/8	10.90	2620	2040	1800	1600	1380
	¾C-4¼ X 4¼-40	1	4-5/8	8-5/8	6.00	1430	1120	980	870	760
		2	10-5/8	14-5/8	9.70	2350	1840	1630	1430	1250
		3	16-5/8	20-5/8	11.20	2680	2090	1840	1630	1410
	¾C-4¼ X 4¼-48	1	4-5/8	8-5/8	6.20	1490	1160	1030	910	790
		2	10-5/8	14-5/8	10.00	2410	1880	1670	1470	1280
		3	16-5/8	20-5/8	11.30	2720	2120	1870	1660	1430
1" Dia. copper	1C-3¼ X 3¼-32	1	3-5/8	7-5/8	3.70	890	690	610	540	470
		2	9-5/8	13-5/8	6.40	1540	1200	1060	940	820
		3	15-5/8	19-5/8	8.40	2020	1580	1390	1230	1070
	1C-3¼ X 3¼-40	1	3-5/8	7-5/8	4.00	960	750	660	590	510
		2	9-5/8	13-5/8	6.80	1630	1270	1120	990	860
		3	15-5/8	19-5/8	7.90	1900	1480	1310	1160	1010
	1C-3¼ X 3¼-48	1	3-5/8	7-5/8	4.30	1030	800	710	630	650
		2	9-5/8	13-5/8	7.10	1700	1330	1170	1040	900
		3	15-5/8	19-5/8	8.00	1920	1500	1320	1170	1020
1" Dia. copper	1C-4¼ X 4¼-32	1	4-5/8	8-5/8	5.40	1290	1010	890	790	680
		2	10-5/8	14-5/8	9.10	2180	1700	1500	1330	1150
		3	16-5/8	20-5/8	10.70	2570	2000	1770	1570	1360
	1C-4¼ X 4¼-40	1	4-5/8	8-5/8	5.90	1410	1100	970	860	750
		2	10-5/8	14-5/8	9.60	2310	1810	1600	1410	1230
		3	16-5/8	20-5/8	11.00	2630	2050	1810	1600	1390
	1C-4¼ X 4¼-48	1	4-5/8	8-5/8	6.10	1470	1140	1010	900	780
		2	10-5/8	14-5/8	9.90	2370	1850	1640	1450	1260
		3	16-5/8	20-5/8	11.10	2670	2080	1840	1630	1410

*EDR - Equivalent Direct Radiation area (for steam heat) per active (finned) lineal foot of tube.

Important Rating Information Performance ratings based on:

- Installation at height shown. (Lower heights are not recommended. For greater heights, refer to EZselect selection software.)
- Entering air temperature of 65°F. (For other temperatures, refer to EZselect selection software.)

- Steam at nominal 1 (actual 0.9) psig and 215°F. (For other conditions, refer to EZselect selection software.)
- Water average temperature (°F) shown and velocity of 3 fps or more. (For lower velocities, refer to EZselect selection software.)

Performance ratings

Model ETO

In BTU/hr per active (finned) lineal foot of tube at entering air temperature of 65°F

Element	Rows of element (on 6-inch centers)	Enclosure height (in inches)	Recommend-ed minimum installed height (in inches)	EDR* (ft ² / ft)	Steam heat	Hot water heat				
					215°F factor of 1.00	190°F factor of 0.78	180°F factor of 0.69	170°F factor of 0.61	160°F factor of 0.53	
Copper/aluminum element										
1 1/4" Dia. copper	1 1/4C-3 1/4 X 3 1/4-32	1	3-5/8	7-5/8	3.90	940	730	650	570	500
		2	9-5/8	13-5/8	6.50	1560	1220	1080	950	830
		3	15-5/8	19-5/8	8.00	1920	1500	1320	1170	1020
	1 1/4C-3 1/4 X 3 1/4-40	1	3-5/8	7-5/8	4.30	1030	800	710	630	550
		2	9-5/8	13-5/8	7.00	1680	1310	1160	1020	890
		3	15-5/8	19-5/8	8.20	1970	1540	1360	1200	1040
	1 1/4C-3 1/4 X 3 1/4-48	1	3-5/8	7-5/8	4.50	1080	840	750	660	570
		2	9-5/8	13-5/8	7.10	1700	1330	1170	1040	900
		3	15-5/8	19-5/8	8.30	1990	1550	1370	1210	1050
1 1/4" Dia. copper	1 1/4C-4 1/4 X 4 1/4-32	1	4-5/8	8-5/8	5.30	1270	990	880	770	670
		2	10-5/8	14-5/8	8.90	2140	1670	1480	1310	1130
		3	16-5/8	20-5/8	10.50	2520	1970	1740	1540	1340
	1 1/4C-4 1/4 X 4 1/4-40	1	4-5/8	8-5/8	5.80	1390	1080	960	850	740
		2	10-5/8	14-5/8	9.50	2280	1780	1570	1390	1210
		3	16-5/8	20-5/8	10.80	2590	2020	1790	1580	1370
	1 1/4C-4 1/4 X 4 1/4-48	1	4-5/8	8-5/8	6.00	1440	1120	990	880	760
		2	10-5/8	14-5/8	9.70	2330	1820	1610	1420	1230
		3	16-5/8	20-5/8	10.90	2620	2040	1810	1600	1390

*EDR - Equivalent Direct Radiation area (for steam heat) per active (finned) lineal foot of tube.

Important Rating Information Performance ratings based on:

- Installation at height shown. (Lower heights are not recommended. For greater heights, refer to EZselect selection software.)
- Entering air temperature of 65°F. (For other temperatures, refer to EZselect selection software.)

- Steam at nominal 1 (actual 0.9) psig and 215°F. (For other conditions, refer to EZselect selection software.)
- Water average temperature (°F) shown and velocity of 3 fps or more. (For lower velocities, refer to EZselect selection software.)

Performance ratings

Model EXO

In BTU/hr per active (finned) lineal foot of tube at entering air temperature of 65°F

Element	Rows of element (on 6-inch centers)	Enclosure height (in inches)	Recommended minimum installed height (in inches)	EDR* (ft ² / ft)	Steam heat	Hot water heat				
					215°F factor of 1.00	190°F factor of 0.78	180°F factor of 0.69	170°F factor of 0.61	160°F factor of 0.53	
Steel element										
1" Dia. steel	1S-3¼ X 3¼-32	1	3-1/2	7-1/2	3.70	890	690	610	540	470
		2	9-1/2	13-1/2	6.50	1570	1230	1080	960	830
		3	15-1/2	19-1/2	9.10	2180	1700	1500	1330	1150
	1S-3¼ X 3¼-40	1	3-1/2	7-1/2	4.00	960	740	660	580	500
		2	9-1/2	13-1/2	7.10	1710	1340	1180	1040	910
		3	15-1/2	19-1/2	9.60	230	1790	1580	1400	1220
	1S-3¼ X 3¼-48	1	3-1/2	7-1/2	4.40	1050	820	730	640	550
		2	9-1/2	13-1/2	7.60	1830	1430	1260	1110	970
		3	15-1/2	19-1/2	10.20	2460	1930	1700	1500	1310
1" Dia. steel	1S-4¼ X 4¼-32	1	4-1/2	8-1/2	4.90	1170	920	810	710	620
		2	10-1/2	14-1/2	8.70	2090	1630	1450	1280	1100
		3	16-1/2	20-1/2	11.50	2770	2160	1910	1690	1470
	1S-4¼ X 4¼-40	1	4-1/2	8-1/2	5.30	1290	1000	890	790	680
		2	10-1/2	14-1/2	9.50	2280	1780	1570	1390	1200
		3	16-1/2	20-1/2	12.10	2920	2270	2010	1780	1540
	1S-4¼ X 4¼-48	1	045	8.5	5.82	1340	1040	920	820	710
		2	105	14.5	10.16	2337	1820	1610	1430	1240
		3	165	20.5	13.09	3012	2350	2080	1840	1600

*EDR - Equivalent Direct Radiation area (for steam heat) per active (finned) lineal foot of tube.

Important Rating Information Performance ratings based on:

- Installation at height shown. (Lower heights are not recommended. For greater heights, refer to EZselect selection software.)
- Entering air temperature of 65°F. (For other temperatures, refer to EZselect selection software.)

- Steam at nominal 1 (actual 0.9) psig and 215°F. (For other conditions, refer to EZselect selection software.)
- Water average temperature (°F) shown and velocity of 3 fps or more. (For lower velocities, refer to EZselect selection software.)

Performance ratings

Model EXO

In BTU/hr per active (finned) lineal foot of tube at entering air temperature of 65°F

Element	Rows of element (on 6-inch centers)	Enclosure height (in inches)	Recommend-ed minimum installed height (in inches)	EDR* (ft ² / ft)	Steam heat	Hot water heat				
					215°F factor of 1.00	190°F factor of 0.78	180°F factor of 0.69	170°F factor of 0.61	160°F factor of 0.53	
Steel element										
1/4" Dia. steel	1¼S-3¼ X 3¼-32	1	3-1/2	7-1/2	3.80	910	710	630	560	480
		2	9-1/2	13-1/2	6.70	1610	1260	1110	980	850
		3	15-1/2	19-1/2	9.30	2230	1740	1540	1360	1180
	1¼S-3¼ X 3¼-40	1	3-1/2	7-1/2	4.10	980	760	680	600	520
		2	9-1/2	13-1/2	7.30	1750	1370	1210	1070	930
		3	15-1/2	19-1/2	9.80	2350	1830	1620	1430	1250
	1¼S-3¼ X 3¼-48	1	3-1/2	7-1/2	4.50	1080	840	750	660	570
		2	9-1/2	13-1/2	7.80	1870	1460	1290	1140	990
		3	15-1/2	19-1/2	10.50	2520	1970	1740	1540	1340
1/4" Dia. steel	1¼S-4¼ X 4¼-32	1	4-1/2	8-1/2	5.00	1200	940	830	730	640
		2	10-1/2	14-1/2	8.90	2140	1670	1480	1310	1130
		3	16-1/2	20-1/2	11.80	2830	2210	1950	1730	1500
	1¼S-4¼ X 4¼-40	1	4-1/2	8-1/2	5.50	1320	1030	910	810	700
		2	10-1/2	14-1/2	9.70	2330	1820	1610	1420	1230
		3	16-1/2	20-1/2	12.40	2980	2320	2060	1820	1580
	1¼S-4¼ X 4¼-48	1	4-1/2	8-1/2	6.00	1440	1120	990	880	760
		2	10-1/2	14-1/2	10.50	2520	1970	1740	1540	1340
		3	16-1/2	20-1/2	13.50	3240	2530	2240	1980	1720
2" Dia. steel	2S-4¼ X 4¼-32	1	4-1/2	8-1/2	5.10	1220	950	840	740	650
		2	10-1/2	14-1/2	9.00	2160	1680	1490	1320	1140
		3	16-1/2	20-1/2	11.30	2710	2110	1870	1650	1440
	2S-4¼ X 4¼-40	1	4-1/2	8-1/2	6.00	1440	1120	990	880	760
		2	10-1/2	14-1/2	10.50	2520	1970	1740	1540	1340
		3	16-1/2	20-1/2	12.60	3020	2360	2080	1840	1600
	2S-4¼ X 4¼-48	1	4-1/2	8-1/2	7.10	1700	1330	1170	1040	900
		2	10-1/2	14-1/2	12.10	2900	2260	2000	1770	1540
		3	16-1/2	20-1/2	14.30	3430	2580	2370	2090	1820

*EDR - Equivalent Direct Radiation area (for steam heat) per active (finned) lineal foot of tube.

Important Rating Information Performance ratings based on:

- Installation at height shown. (Lower heights are not recommended. For greater heights, refer to EZselect selection software.)
- Entering air temperature of 65°F. (For other temperatures, refer to EZselect selection software.)

- Steam at nominal 1 (actual 0.9) psig and 215°F. (For other conditions, refer to EZselect selection software.)
- Water average temperature (°F) shown and velocity of 3 fps or more. (For lower velocities, refer to EZselect selection software.)

Performance ratings

Model EXO

In BTU/hr per active (finned) lineal foot of tube at entering air temperature of 65°F

Element	Rows of element (on 6-inch centers)	Enclosure height (in inches)	Recommend- ed minimum installed height (in inches)	EDR* (ft ² / ft)	Steam heat	Hot water heat				
					215°F factor of 1.00	190°F factor of 0.78	180°F factor of 0.69	170°F factor of 0.61	160°F factor of 0.53	
Copper/aluminum element										
¾" Dia. copper	¾C-3¼ X 3¼-32	1	3-1/2	7-1/2	4.40	1080	840	740	660	570
		2	9-1/2	13-1/2	8.10	1950	1530	1340	1190	1040
		3	15-1/2	19-1/2	11.30	2710	2110	1870	1650	1430
	¾C-3¼ X 3¼-40	1	3-1/2	7-1/2	4.80	1170	910	800	710	620
		2	9-1/2	13-1/2	8.50	2060	1610	1410	1250	1090
		3	15-1/2	19-1/2	11.70	2810	2190	1930	1710	1480
	¾C-3¼ X 3¼-48	1	3-1/2	7-1/2	5.10	1220	950	840	740	650
		2	9-1/2	13-1/2	8.80	2130	1660	1460	1290	1130
		3	15-1/2	19-1/2	11.70	2810	2190	1930	1710	1480
¾" Dia. copper	¾C-4¼ X 4¼-32	1	4-1/2	8-1/2	6.40	1530	1190	1060	930	810
		2	10-1/2	14-1/2	11.30	2720	2120	1870	1660	1440
		3	16-1/2	20-1/2	15.40	3700	2890	2560	2260	1960
	¾C-4¼ X 4¼-40	1	4-1/2	8-1/2	7.00	1680	1300	1160	1020	880
		2	10-1/2	14-1/2	12.00	2890	2250	1990	1760	1530
		3	16-1/2	20-1/2	15.90	3820	2980	2640	2330	2020
	¾C-4¼ X 4¼-48	1	4-1/2	8-1/2	7.10	1770	1380	1220	1090	940
		2	10-1/2	14-1/2	12.30	2950	2310	2050	1800	1570
		3	16-1/2	20-1/2	16.00	3840	2990	2650	2340	2040
1" Dia. copper	1C-3¼ X 3¼-32	1	3-1/2	7-1/2	4.40	1060	830	730	650	560
		2	9-1/2	13-1/2	8.00	1920	1500	1320	1170	1020
		3	15-1/2	19-1/2	11.10	2660	2070	1840	1620	1410
	1C-3¼ X 3¼-40	1	3-1/2	7-1/2	4.80	1150	900	790	700	610
		2	9-1/2	13-1/2	8.40	2020	1580	1390	1230	1070
		3	15-1/2	19-1/2	11.50	2760	2150	1900	1680	1460
	1C-3¼ X 3¼-48	1	3-1/2	7-1/2	5.00	1200	940	830	730	640
		2	9-1/2	13-1/2	8.70	2090	1630	1440	1270	1110
		3	15-1/2	19-1/2	11.50	2760	2150	1900	1680	1460
1" Dia. copper	1C-4¼ X 4¼-32	1	4-1/2	8-1/2	6.30	1500	1170	1040	920	800
		2	10-1/2	14-1/2	11.10	2670	2080	1840	1630	1420
		3	16-1/2	20-1/2	15.10	3630	2840	2510	2220	1930
	1C-4¼ X 4¼-40	1	4-1/2	8-1/2	6.90	1650	1280	1140	1000	870
		2	10-1/2	14-1/2	11.80	2840	2210	1960	1730	1500
		3	16-1/2	20-1/2	15.60	3750	2930	2590	2290	1990
	1C-4¼ X 4¼-48	1	4-1/2	8-1/2	7.20	1740	1360	1200	1070	930
		2	10-1/2	14-1/2	12.10	2900	2270	2010	1770	1540
		3	16-1/2	20-1/2	15.70	3770	2940	2600	2300	2000

*EDR - Equivalent Direct Radiation area (for steam heat) per active (finned) lineal foot of tube.

Important Rating Information Performance ratings based on:

- Installation at height shown. (Lower heights are not recommended. For greater heights, refer to EZselect selection software.)
- Entering air temperature of 65°F. (For other temperatures, refer to EZselect selection software.)

- Steam at nominal 1 (actual 0.9) psig and 215°F. (For other conditions, refer to EZselect selection software.)
- Water average temperature (°F) shown and velocity of 3 fps or more. (For lower velocities, refer to EZselect selection software.)

Performance ratings

Model EXO

In BTU/hr per active (finned) lineal foot of tube at entering air temperature of 65°F

Element	Rows of element (on 6-inch centers)	Enclosure height (in inches)	Recommend-ed minimum installed height (in inches)	EDR* (ft ² / ft)	Steam heat	Hot water heat				
					215°F factor of 1.00	190°F factor of 0.78	180°F factor of 0.69	170°F factor of 0.61	160°F factor of 0.53	
Copper/aluminum element										
1 1/4" Dia. copper	1 1/4C-3 1/4 X 3 1/4-32	1	3-1/2	7-1/2	4.60	1100	860	760	670	580
		2	9-1/2	13-1/2	8.10	1940	1510	1340	1180	1030
		3	15-1/2	19-1/2	11.50	2760	2150	1900	1680	1460
	1 1/4C-3 1/4 X 3 1/4-40	1	3-1/2	7-1/2	5.00	1200	940	830	730	640
		2	9-1/2	13-1/2	8.60	2060	1610	1420	1260	1090
		3	15-1/2	19-1/2	11.90	2860	2230	1970	1740	1520
	1 1/4C-3 1/4 X 3 1/4-48	1	3-1/2	7-1/2	5.20	1250	980	860	760	660
		2	9-1/2	13-1/2	8.80	2110	1650	1460	1290	1120
		3	15-1/2	19-1/2	11.90	2860	2230	1970	1740	1520
1 1/4" Dia. copper	1 1/4C-4 1/4 X 4 1/4-32	1	4-1/2	8-1/2	6.20	1490	1160	1030	910	790
		2	10-1/2	14-1/2	11.00	2640	2060	1820	1610	1400
		3	16-1/2	20-1/2	15.00	3600	2810	2480	2200	1910
	1 1/4C-4 1/4 X 4 1/4-40	1	4-1/2	8-1/2	6.80	1630	1270	1120	990	860
		2	10-1/2	14-1/2	11.70	2810	2190	1940	1710	1490
		3	16-1/2	20-1/2	15.50	3720	2900	2570	2270	1970
	1 1/4C-4 1/4 X 4 1/4-48	1	4-1/2	8-1/2	7.20	1730	1350	1190	1060	920
		2	10-1/2	14-1/2	12.00	2880	2250	1990	1760	1530
		3	16-1/2	20-1/2	15.60	3740	2920	2580	2280	1980

*EDR - Equivalent Direct Radiation area (for steam heat) per active (finned) lineal foot of tube.

Important Rating Information Performance ratings based on:

- Installation at height shown. (Lower heights are not recommended. For greater heights, refer to EZselect selection software.)
- Entering air temperature of 65°F. (For other temperatures, refer to EZselect selection software.)

- Steam at nominal 1 (actual 0.9) psig and 215°F. (For other conditions, refer to EZselect selection software.)
- Water average temperature (°F) shown and velocity of 3 fps or more. (For lower velocities, refer to EZselect selection software.)

Dimensions and data

ETO, EXO and STEL

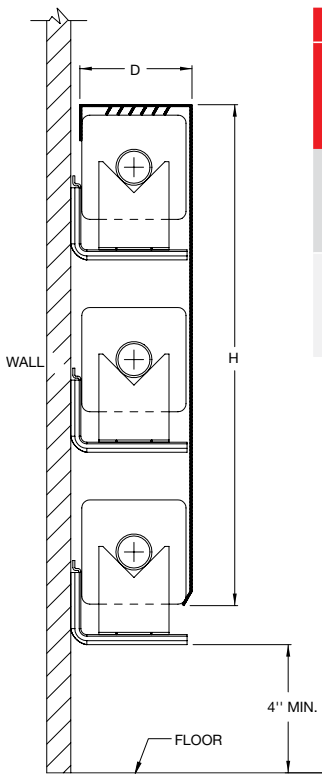

ETO			
Fin sizes for finned tube*	Rows of finned tube	D (depth)	H (height)
3-1/4" x 3-1/4"	1	3-1/2"	3-5/8"
	2		9-5/8"
	3		15-5/8"
4-1/4" x 4-1/4"	1	4-1/2"	4-5/8"
	2		10-5/8"
	3		16-5/8"

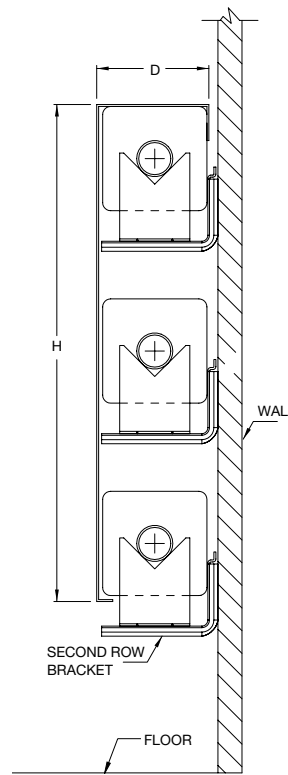

ETO			
Fin sizes for finned tube*	Rows of finned tube	D (depth)	H (height)
3-1/4" x 3-1/4"	1	3-1/2"	3-1/2"
	2		9-1/2"
	3		15-1/2"
4-1/4" x 4-1/4"	1	4-1/2"	4-1/2"
	2		10-1/2"
	3		16-1/2"

- Note:
- *Consult factory to fit tube with 2-3/4" x 4" fins.
 - Enclosures are available in 1 foot to 8 foot lengths in 6 inch increments.

Sloped economy STEL

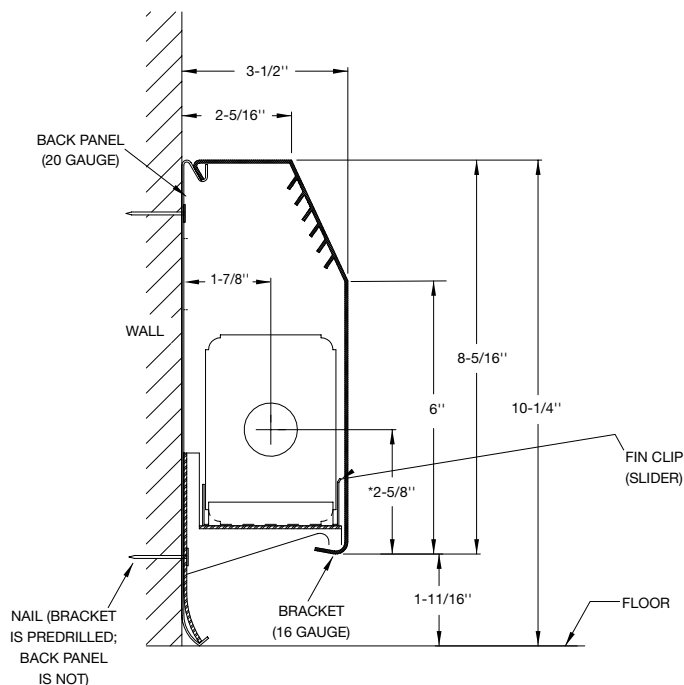

- Notes:
- *Center lines are based on 1" copper tube.

Accessories

STEL

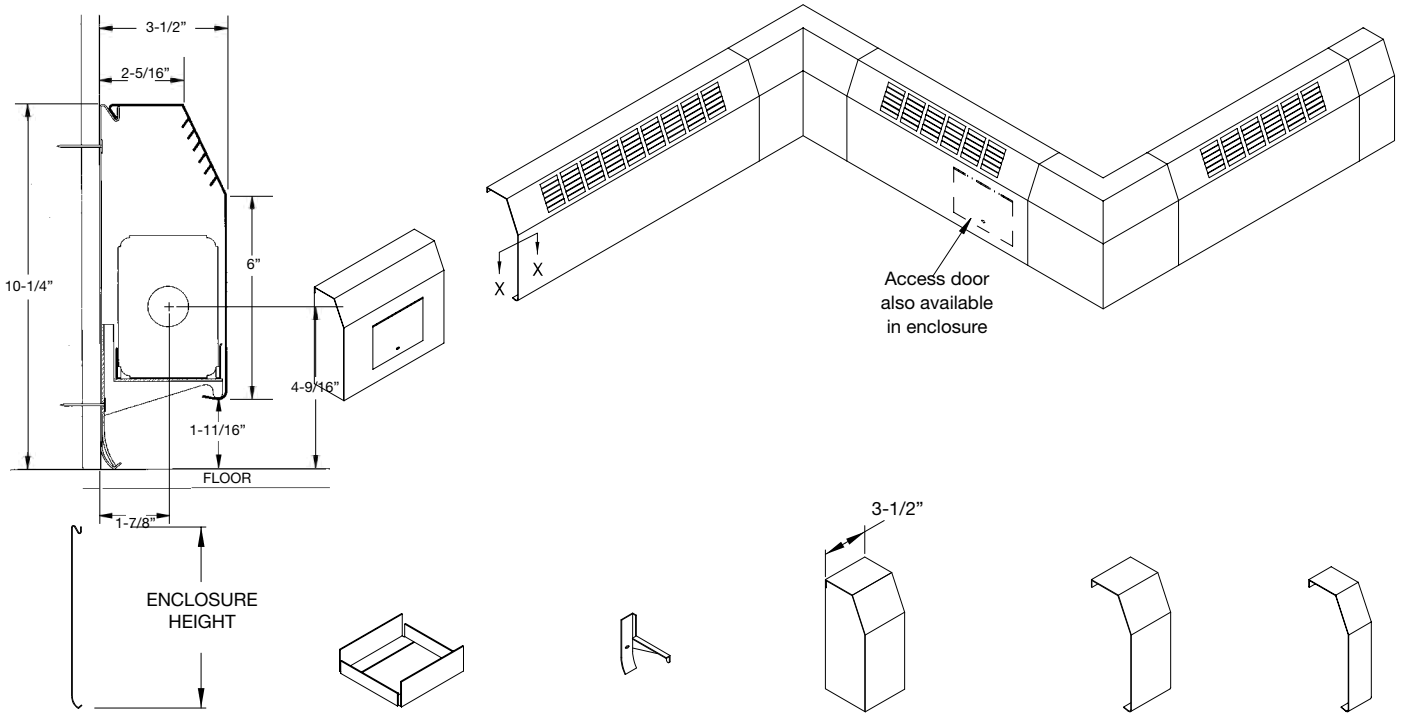

"STEL-BP"
Back panel

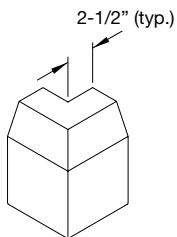

"STEL-AL"
Element slider

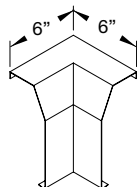

"STELBRKT"
Element bracket



"EC"
End cap
(left hand shown)

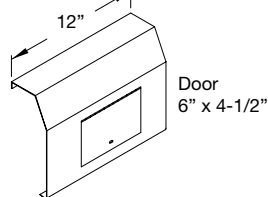

"WT"
Wall trim strip
3-1/2", 5", 7-1/2"



"JNR"
Joining trim
strip 2"

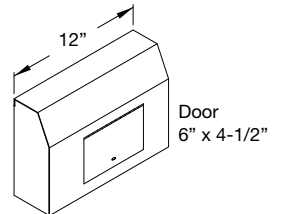

"OC"
Outside corner

"IC"
Inside corner



Knob damper

"AP"
Access panel with access door,
overlapping style only (security
lock opt.)

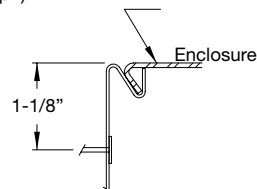

Back panel detail

"AC"
End cap with access door,
left side shown (security lock opt.)

Accessories

ETO and EXO

ETO

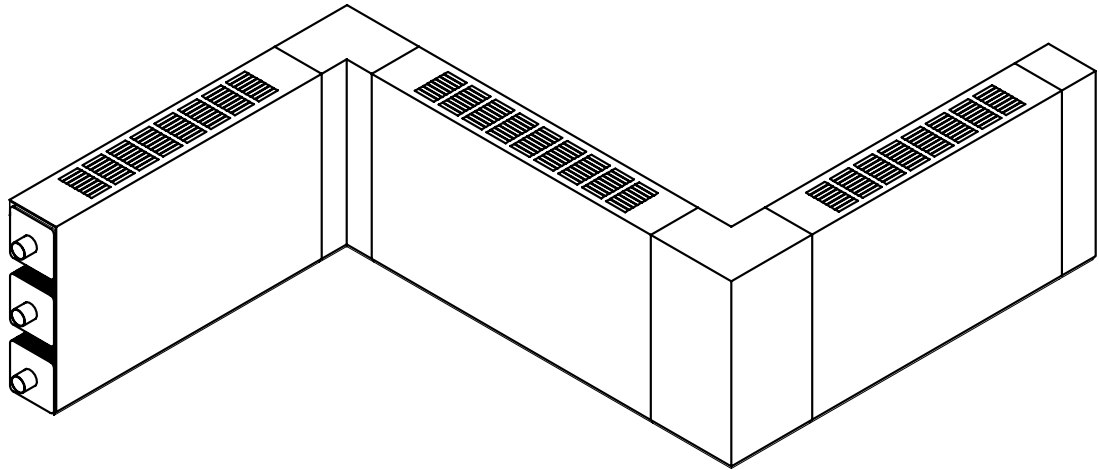

EXO

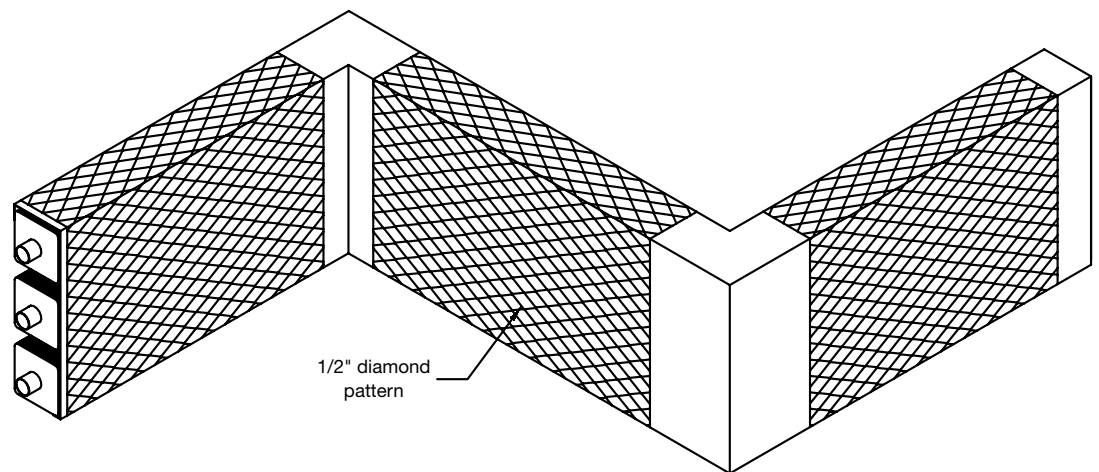

3-1/2" 3-1/2"

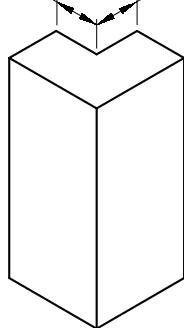

"OC"
Outside corner

7" or 8" 7" or 8"

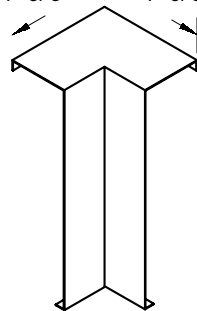

"IC"
EXO (8") or ETO (7")
inside corner

1" or
3-1/2"

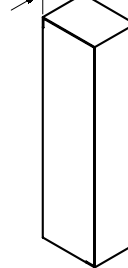

"EC"
EXO (1") or ETO (3-1/2")
end cap (left hand shown)

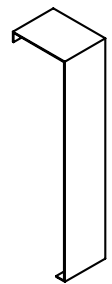

"WT"
Wall trim strip
3-1/2", 5", 7-1/2"



Slip-in
second row
bracket

Design data

The Institute of Boiler and Radiator Manufacturers sponsored a test program at the University of Illinois to determine the effect of water velocity on heat output of various sizes of finned tubed element.

The results of this test show that when the water velocity falls below 0.4 f.p.s., the flow changes from turbulent to streamline. With systems designed at water velocities below this point the output cannot be accurately predicted so should always be avoided.

Figure 1 shows rating factors that can be utilized when the water velocity falls below 3 f.p.s.

It is recommended when designing low-load systems that the water velocity be a key factor in element selection.

For more information on this topic, please refer to the 1969 equipment volume of ASHRAE Guide and Data Book Page #393.

Figure 2
Pipe water capacities and quantities circulated at velocity of 3 feet per second*

Pipe Size	Gallons per linear foot	Gallons per minute*	Pounds per hour*
1/2"	.016	2.88	1440
3/4"	.023	4.14	2070
1"	.040	7.20	3600
1-1/4"	.063	11.34	5660
1-1/2"	.102	18.36	9160
2"	.170	30.60	15300
2-1/2"	.275	49.50	24850
3"	.390	70.20	35000

Note:
 ■ *3 feet per second velocity is basis for hot water rating factors shown on this page

$$\text{Velocity ft./sec.} = \frac{\text{lbs./hr.}}{(\text{gal./ft.}) (3600) (8.3)}$$

The effects of water velocity on finned tube output

Figure 1
Effect of Water Velocity on Finned Tube Output

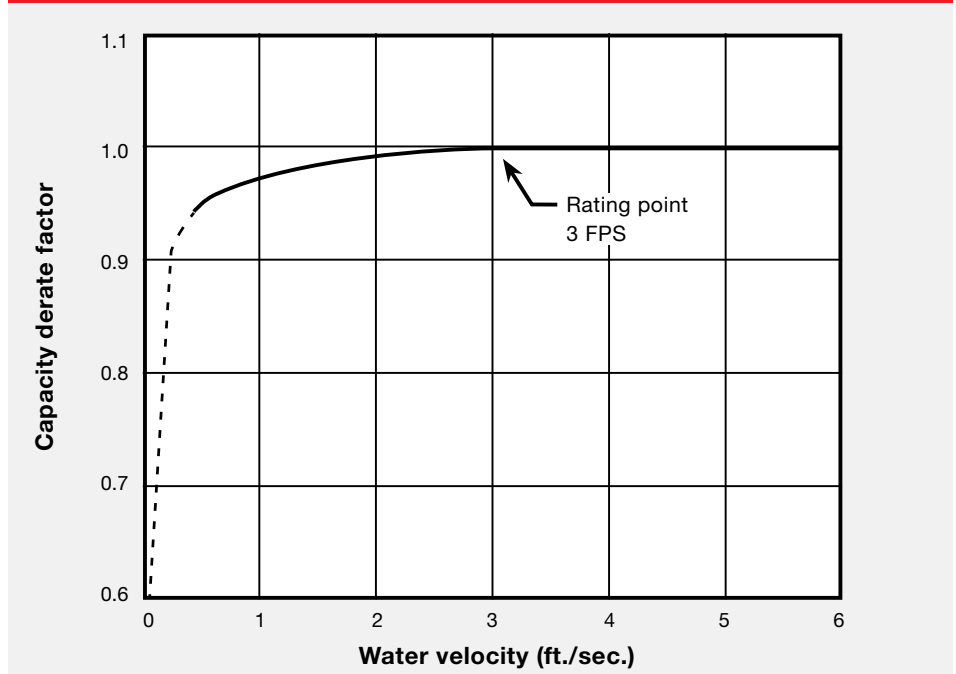

Note:
 ■ ---- below critical velocity

Figure 3
Expansion in steel and copper piping

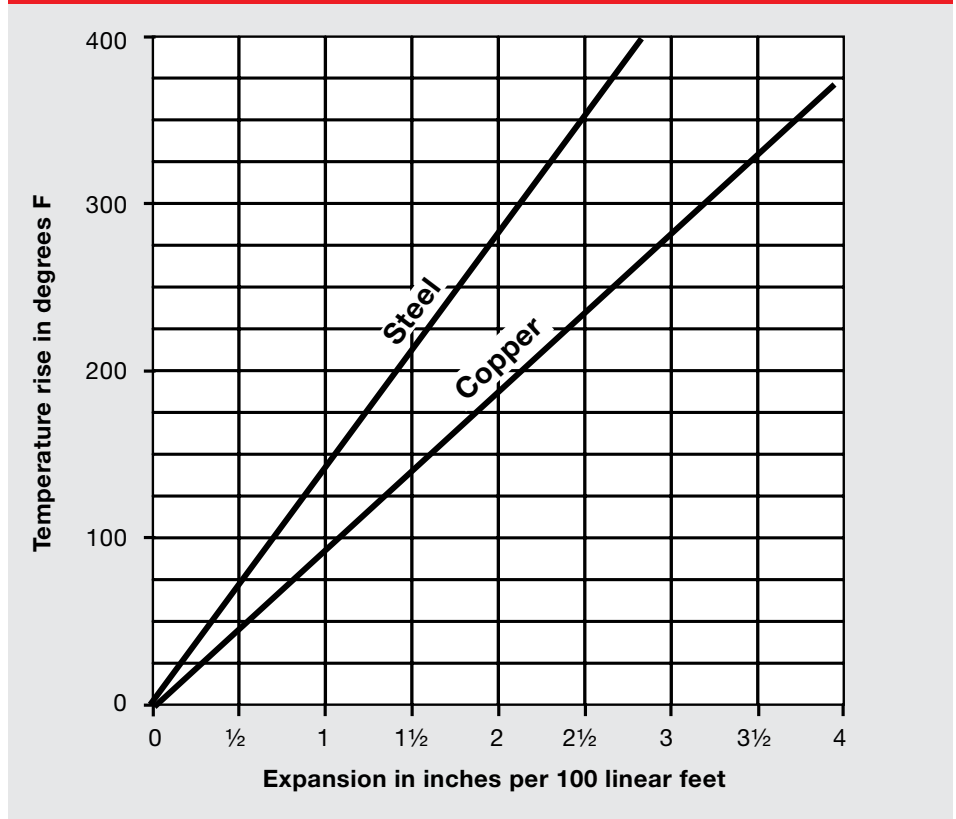

Design data

Figure 4 - Inlet vs. output / BTUH capacity reduction

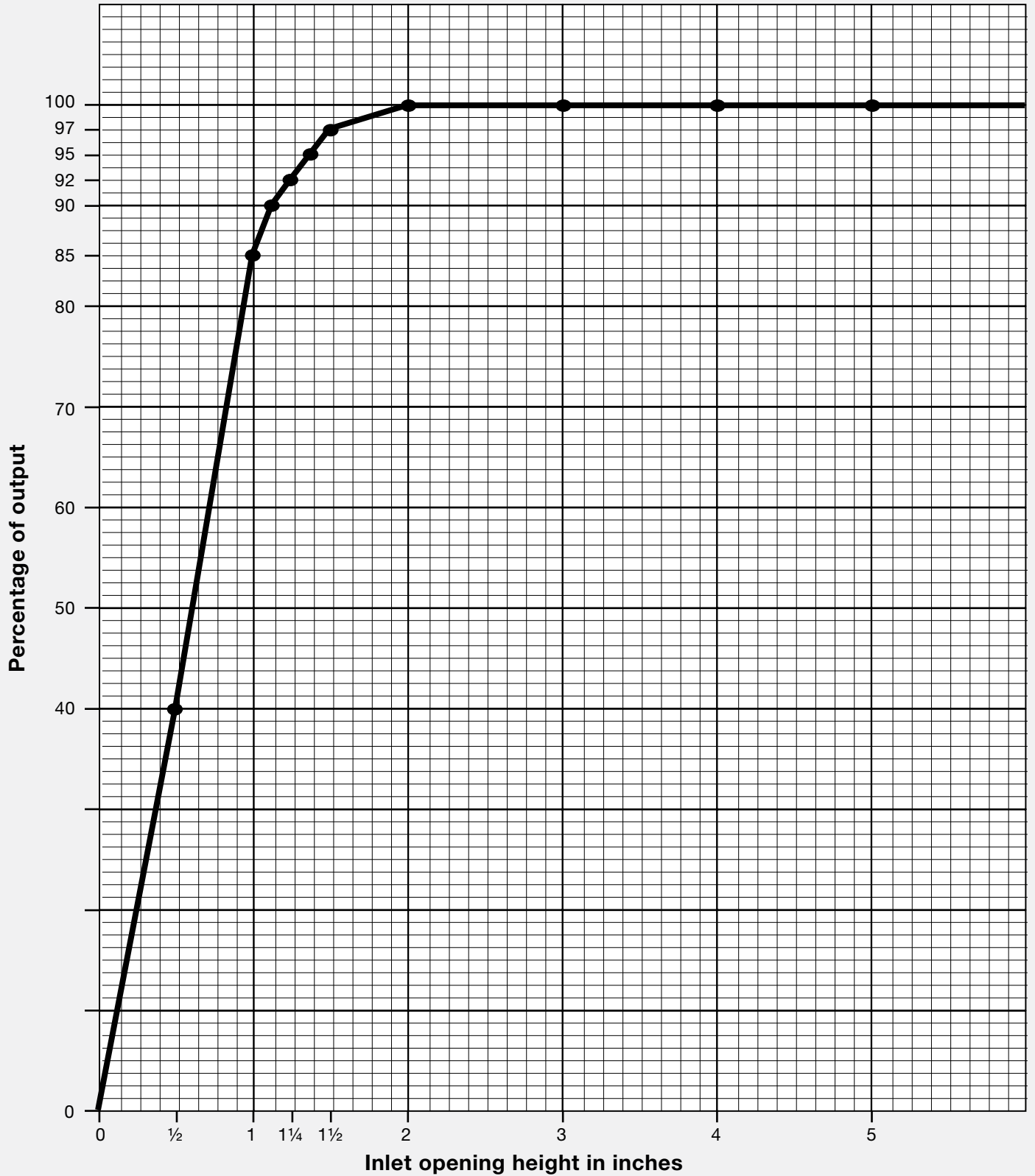

Recommended minimum inlet opening 1-1/2". Applicable to commercial finned-tube only

Mechanical specifications

General

Furnish and install finned tube heating elements and enclosures as indicated on plans, with required mounting components and accessories. Material shall be manufactured in accordance with Zehnder Rittling's High Quality Standards.

Steel heating elements

Steel heating elements shall consist of 0.027" thick galvanized fins permanently bonded to high pressure A106 seamless schedule 40B steel tubing by mechanically expanding the steel tubing to the steel fins. Steel tube wall thickness; 1" dia. - 0.133", 1-1/4" dia. - 0.140", 2" dia. - 0.154", prior to tube expansion.

Guaranteed working

pressures:

1" IPS - 780 psig at temperature up to 650°F. 1-1/4" IPS - 660 psig at temperatures up to 650°F.
2" IPS - 405 psig at temperatures up to 650°F.

Copper-aluminum heating elements

Copper-aluminum heating elements shall consist of 0.016" thick, 1100 grade aluminum fins permanently bonded to lightly annealed copper alloy 122 seamless drawn tubing by mechanically expanding the copper tubing to the aluminum fins. Copper tube wall thickness; 3/4" dia - 0.020", 1" dia. - 0.025", 1-1/4" dia. - 0.028", prior to tube expansion. Copper tube meets the following ASTM standard designations: ASTM B42, ASTM B68, ASTM B75, ASTM B88, ASTM B111, ASTM B152, ASTM B280.

Guaranteed working pressures:

1-1/4" CU - 194 psig at temperatures up to 300°F. 1" CU - 204 psig at temperature up to 300°F. 3/4" CU - 218 psig at temperatures up to 300°F.

ETO enclosures and accessories

Enclosures shall be of the type as shown on the drawings. Enclosures shall be manufactured from 14, 16 or 18 gauge cold rolled steel. Enclosures to be designed to snap on and rest directly on the heating element. No sheet metal screws or other fastening devices shall be visible.

EXO enclosures and accessories

Enclosures shall be of the type as shown on the drawings. Enclosures shall be manufactured from 16 or 18 gauge expanded metal. Enclosures to be designed to snap on and rest directly on the heating element. Edges of enclosure to be hemmed to provide a rounded edge. No sheet metal screws or other fastening devices shall be visible.

ETO/EXO hanger brackets

All hanger brackets shall be die formed for rigidity. Brackets to be designed to support the heating element and enclosure. Brackets to be suitable for one, two or three row applications.

All hangers must provide for lengthwise movement of elements during expansion and contraction as well as aligning elements to prevent contact with brackets, walls or enclosures.

Paint:

All enclosures and accessories shall be degreased and chemically phosphatized before application of a durable, attractive, electrostatic epoxy powder coating. Decorator colors are available from Zehnder Rittling's color selector chart.

Special applications

Zehnder Rittling's reputation for leadership in commercial heating systems design and fabrication thrives on a demonstrated ability to modify or adapt components from our vast standard inventory and to break new ground with innovative applications.

Our ingenuity and expertise free architects from the constraints of hydronic-heating conventions. We can, for instance, customize enclosures to any dimensions in stainless, textured embossed, or perforated steel for installation anywhere: in ceilings, walls, or trenches. We'll angle finned tube systems to match the wall or slope of a floor. We can even fabricate the enclosure to match the curve of a wall. We'll fabricate all copper heating elements, bronze anodized and other specialty outlet grilles, or pipe enclosures without grilles. Challenge us and we'll build it!

If you have a special application you would like us to evaluate, please call to arrange a consultation with a Zehnder Rittling expert.

The brand with the best indoor climate solutions.

FOUR COMPLEMENTARY PRODUCT LINES

The broad and clearly structured portfolio from the Zehnder Group is split into four product lines. Consequently, we can provide the right product, the perfect system and the matching service for all types of projects - from new builds to renovations, single- or multiple- family homes, as well as commercial projects. This variety ensures that our wealth of experience is continuously expanding, providing tangible added value to our customers on a daily basis.



Decorative radiators

Our individual decorative radiators for living and bathrooms not only make a home warmer but also more attractive. Created by renowned designers, they impress with excellent functionality.

NUMBERS THAT SPEAK FOR THEMSELVES

MANUFACTURER OF THE

1ST

STEEL RADIATOR IN
THE WORLD

121

YEARS OF INNOVATIVE TRADITION

AROUND

3,000

EMPLOYEES

FOUNDED IN

1895

REPRESENTED IN
COUNTRIES

19

1,800,000

TONNES OF CO₂ SAVED SINCE 2005

WARRANTY

Zehnder guarantees its products to be free from defects in material and workmanship for a period of one year from date of shipment from our Buffalo, New York factory.

Should there be any defects in the good(s), the purchaser should promptly notify Zehnder and upon receipt of written consent from Zehnder, the purchaser shall return the defective good(s) to the factory for inspection with freight prepaid. If inspection shows the goods to be defective, Zehnder will at its discretion repair or replace the said item(s).

Defects arising from damage due to shipment, improper installation, negligence or misuse by others are not covered by this warranty.



Comfortable indoor ventilation

Our comfortable indoor ventilation is energy-efficient and provides a healthy indoor climate. It promotes the well-being of the occupants and increases the value of the property.



Heating and cooling ceiling systems

Zehnder heating and cooling ceiling systems are convenient and energy-efficient for heating and cooling. They are perfectly attuned to the relevant environment.



Clean air solutions

Clean air solutions from Zehnder reduce the level of dust in the air, create a healthier working climate and reduce the amount of cleaning required.

BEST CLIMATE IN THE WORLD

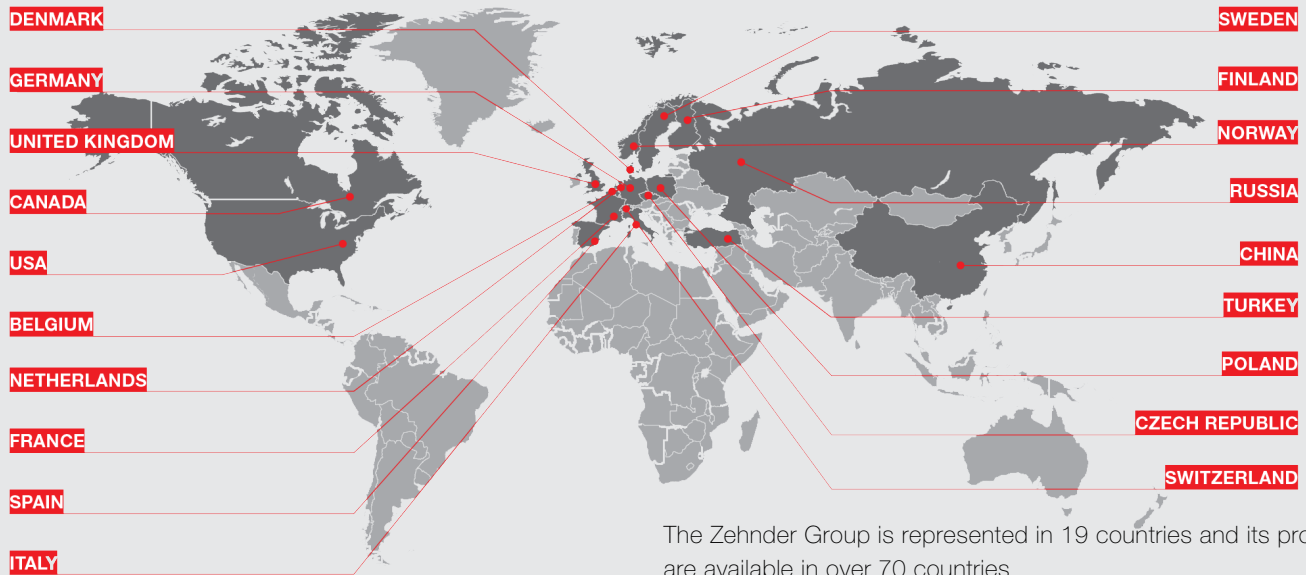

The Zehnder Group is represented in 19 countries and its products are available in over 70 countries

This warranty is extended only to the original purchaser from Zehnder.

IMPORTANT: Approved submittal documentation, specific to each project, supersedes the general guidelines contained within this document.

The Zehnder brand offers excellent indoor climate solutions within the sectors of decorative radiators, clean air solutions, comfortable indoor ventilation and heating and cooling ceiling systems.

