

Rittling Unit Heaters

Catalog



Zehnder – everything you need to create a comfortable, healthy and energy-efficient indoor climate

Heating, cooling, fresh and clean air: at Zehnder, you will find everything you need to create a comfortable, healthy and energy-efficient indoor climate. Zehnder's wide and clearly structured portfolio can offer the right product for any project, be it private, public or commercial, new build or refurbishment. And where service is also concerned, you'll find that Zehnder is "always around you."

Heating

At Zehnder, **Heating** doesn't just come in the form of designer radiators. We offer solutions in all shapes and sizes, from radiant ceiling panels to heat pumps with integrated ventilation devices.

- Designer radiators
- Compact energy station with integrated heat pump
- Heating and cooling ceiling systems
- Comfortable indoor ventilation with heat recovery



Cooling

Zehnder also offers sophisticated solutions for indoor **Cooling**. These range from cooling ceiling systems to comfortable indoor ventilation with a supply of pre-cooled fresh air.

- Heating and cooling ceiling systems
- Compact energy station with heat pump and brine pipe
- Comfortable indoor ventilation with geothermal heat exchanger for fresh air pre-cooling



Fresh Air

Fresh Air – a product range with a long tradition at Zehnder. Zehnder Comfosystems provides products and solutions for comfortable indoor ventilation with heat recovery for houses and apartments, for new builds and for renovation projects.

- Comfortable indoor ventilation
- Compact energy station with integrated ventilation device



Clean Air

Zehnder Clean Air Solutions provide Clean Air in buildings particularly prone to dust. In residential applications, the comfortable indoor ventilation provided by Zehnder Comfosystems filters external pollutants out of the air.

- Comfortable indoor ventilation with integrated fresh-air filter
- Compact energy station with integrated fresh-air filter
- Systems for clean air

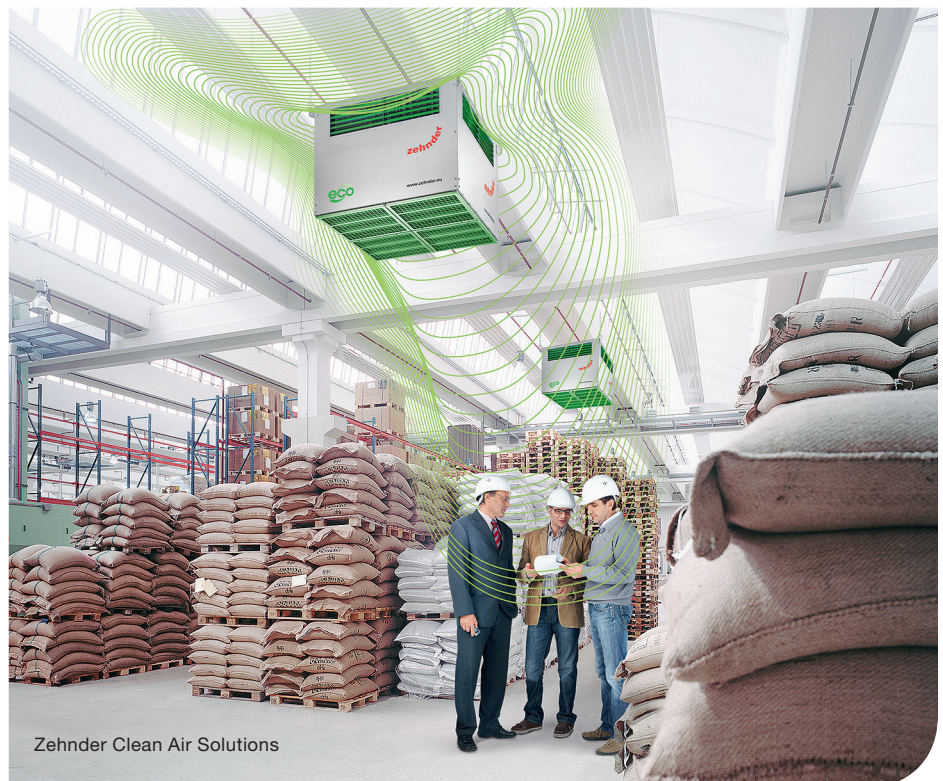

Rittling Unit Heaters

Uniform heating in large open areas

Rittling Unit Heaters provide uniform heating you can count on in large open areas. Our high efficiency units offer low installed costs and provide large heating loads without the need for extensive ductwork systems.

Over the past 15 years, Zehnder Rittling has refined the Rittling Unit Heater design, resulting in an energy-efficient, highly effective product. A combination of smaller units and higher CFM models are available to fill the need for a variety of mounting locations for optimal heat distribution. Utilize the horizontal and vertical louvers in your design for complete directional control, as Rittling Unit Heaters perform at peak efficiency when the airflow is directed to the areas of greatest heat loss.

Contact your Zehnder Rittling Regional Sales Manager for assistance with the benefits of installing our products in accordance with ASHRAE guidelines.



General information	1
Design benefits	2
Application guidelines	4
Performance data	5
Model identification	7
Options	8
Accessories	10
Dimensions and data	11
Mechanical specifications	14
Warranty	Back cover

Reliability and energy-efficient control

Engineering excellence and contemporary design

With more than 60 years experience in the design and manufacture of hydronic heating and cooling systems, Rittling understands your need for efficient heating/cooling equipment that will compliment the décor. Rittling Unit Heaters offer the latest in attractive design and are engineered to provide years of reliable operation and energy-efficient comfort.

Meet specific heating requirement

Rittling steam/hot water unit heaters are available in a wide range of models and airflow arrangements to satisfy the demands of your specifications.

Safety and ease of installation and maintenance

All units include solderless ring terminal connections with vinyl-insulated barrels allowing for easy electrical connection. Optional suspension alternatives are available for easy unit mounting. All unit components are factory tested and coils are leak tested under pressure to ensure proper function when units arrive on the job site.

Motor reliability

All unit heater motors are totally enclosed. All motors, with the exception of 3-phase motors, include thermal overload protection.

Application flexibility

Air distribution is virtually unlimited. Horizontal models are furnished with louvers for directional control of heated air. Vertical units can be furnished with optional air diffusion accessories or standard configuration. Side piping connection configuration on small RH models allows for low clearance installations. Large RH and all RV models have steel male NPT threaded connections. Explosion-proof and 3-phase motors are offered for flexible application.

Attractive styling

Horizontal models have squared off, picture frame style fronts for a clean, defined appearance. Rugged, reinforced 18-GA cold rolled steel construction is die-formed and true. Vertical models are attractive and formed of 16-GA cold rolled steel. Louvers on RH units are rounded off and are aesthetically pleasing. All Rittling unit heaters are treated for corrosion-resistance and finished with a durable epoxy-based gray textured powder coating.

Quiet operation

All unit heaters offer smooth and consistent airflow. All motor horse-power and fan configuration chosen for quiet operation and efficient air output. Air is drawn through smooth, unobstructed venturis. Horizontal units have an additional low speed motor tapping for increased noise reduction.

Design benefits: Horizontal air delivery

A. Coil

- Sturdy, mechanically bonded copper/aluminum coil with twelve fins per inch with 1/2" nominal tubes and 0.028" tube wall thickness
- High BTU capacity
- Coils are tested at 275 psig air under water. Coils are suitable for operating up to 150 psig steam or 220 psig water and 375 °F
- Fins are continuous across width and depth of coil and are vertically oriented to resist collection of dirt and foreign particles

B. Enclosure

- Rugged 18-gauge casing protects against impact and abuse
- Two-piece enclosure allows for ease of maintenance
- Durable and attractive gray textured epoxy powder coating is standard

C. Louvers

- Adjustable horizontal louvers are standard for adjustment of air distribution
- Constructed of rigid 18-gauge steel
- Color matched to enclosure for consistent appearance

D. Piping connection

- NPT connections permit quick and easy piping with no additional components needed
- Mounted to casing for rigidity

E. Mounting hardware

- Heavy duty threaded hardware allows unit to be mounted with threaded rod
- Optional pipe hanger kit available for mounting unit with threaded pipe

F. Formed air inlet/outlet

- Die-formed venturi inlet draws air smoothly into unit for maximum airflow

G. Motor

- All motors are totally enclosed, permanently lubricated for extended, reliable motor life
- Low operating cost and quiet operation
- When teamed with optional variable speed control, fan speed adjustment is infinite
- Equipped with thermal overload protection (except 3-phase motors)
- Junction box for field electrical connection

H. Fan

- Lightweight and dynamically balanced
- Designed to move air efficiently with minimum power requirement

I. Finger proof fan guard

- Standard equipment
- Securely mounts motor to unit while absorbing vibration with rubber isolation mounts

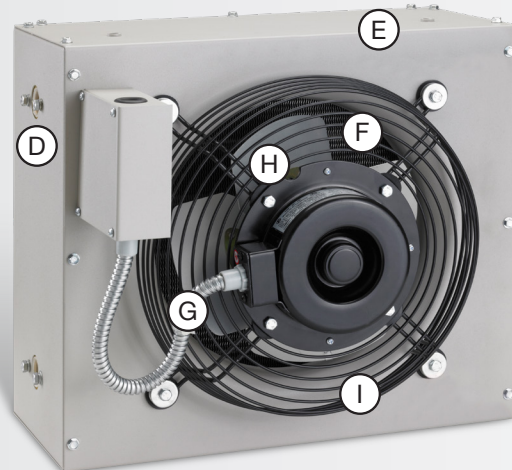
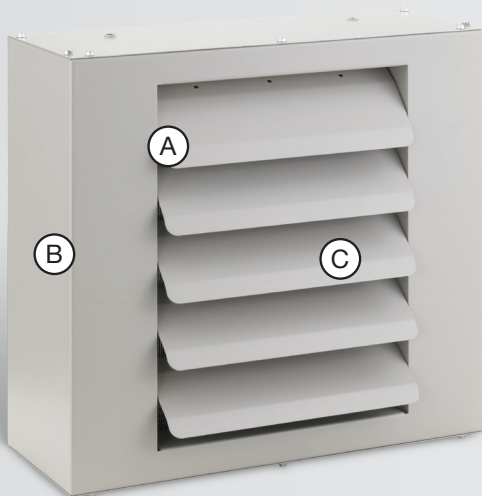

Design benefits: Vertical air delivery

A. Coil

- Sturdy, mechanically bonded copper/aluminum formed coil with 12 fins per inch with 1/2" nominal tubes between extra-heavy steel pipe connections and 0.028" tube wall thickness
- High BTU capacity
- Coils are tested at 275 psig air under water. Coils are suitable for operating up to 150 psig steam or 220 psig water and 375 °F
- Fins are continuous along width and depth and are vertically oriented to resist collection of dirt and foreign particles

B. Formed air inlet/outlet

- Die-formed venturi outlet draws air through unit for maximum airflow

C. Air diffusion

- Multiple arrangements available for unlimited air diffusion patterns
- Accessories are finished with epoxy-based powder coating to match unit

D. Finger proof fan guard

- Standard equipment
- Gives 100% safety confidence for mounting in any area
- Constructed of painted steel rod

E. Fan

- Lightweight, dynamically balanced
- Designed to move air efficiently and quietly with minimum power requirement

F. Casing

- Rugged 16-gauge casing protects against impact and abuse
- Separate top and bottom enclosure pieces allow for ease of maintenance
- Attractive gray textured epoxy powder coating is standard and durable

G. Motor

- All motors are totally enclosed, permanently lubricated for extended, reliable motor life
- Low operating cost and quiet operation

- Designed for easy motor removal, important for high ceiling applications
- Equipped with thermal overload protection (except 3-phase motors)
- High efficiency

H. Mounting hardware

- Heavy duty threaded hardware allows unit to be mounted with threaded rod
- Optional pipe hanger kit (requires 2) available for mounting unit with threaded pipe

I. Junction box

- All unit wiring is contained in an electrical junction box that is mounted to the Rittling Unit Heater casing

J. Piping connection

- Durable steel header has external NPT threads for easy connection

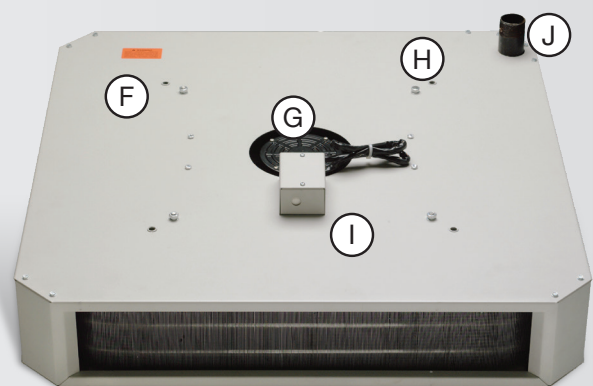
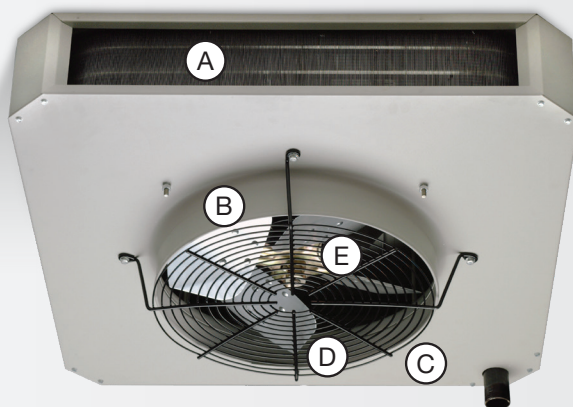

Application guidelines

The first step in the design of a job is typically to determine the heat loss. Refer to ASHRAE and others for publications on the basic methodology used in calculating the building or area's heat loss. Special attention should be paid to the building type (architecturally) and application placement (area use) in this procedure.

The second step is to decide the necessary engineering data for design conditions such as CFM, Leaving air temperature, quantity and location of units, based on the specific Rittling Unit Heater model selected.

Steam/hot water Rittling Unit Heaters' versatility offers a wide selection of outputs and airflows allowing almost unlimited flexibility in job design.

Keep the following guidelines in mind when designing any job using steam/hot water Rittling Unit Heaters:

- Always direct airflow to regions of greatest heat loss.
- Use louvers for adjustment of throw length and complete directional control of airflow.
- Mount units at the lowest practical and allowable level.
- Select lower CFM models for lower installation heights and heavily occupied areas. Select higher CFM models for areas where higher installation is required.
- More, smaller units will provide better heat distribution than fewer larger units.
- Watch Leaving air temperatures on units mounted at lower levels or in heavily occupied areas to ensure that air is warm enough to avoid drafts being felt.
- Sound classifications: Rittling Unit Heaters provide exceptional heat output while considering the nuisance of a loud unit. All units were designed to minimize sound created by airflow and motor operation by careful component selection and inlet geometry. Sound Classification Table to the right shows typical rooms and their corresponding sound class rating.

Typical arrangements

Manufacturing plant

Typical arrangement showing air flow patterns.

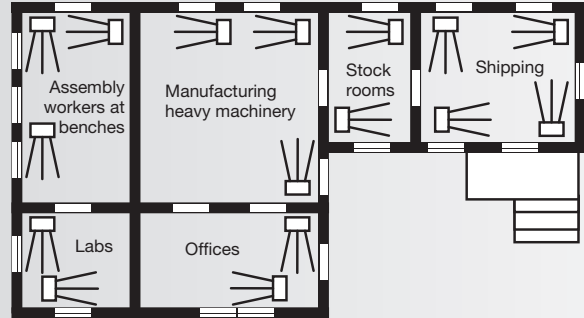

Note: Diagram is not to scale

Large exposed area

A large square area with exposed walls and roof; units are blanketing all exposed surfaces.

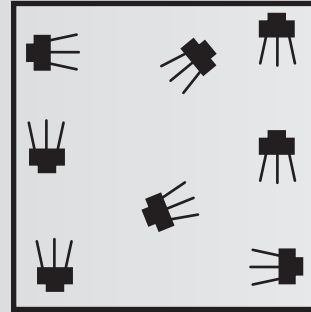

Narrow exposed area

A narrow area with four exposed walls either with or without roof exposure.

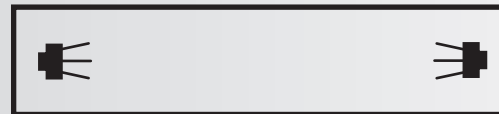

A small area with exposed walls requiring two units.

Sound class ratings*

Type of room or building	Sound class rating
Schools, offices, libraries, hospitals, foyers, rest rooms	I
Showrooms, department stores, clubhouses, commercial dining facilities	II
Large lobbies, warehouse stores, gymnasiums, bars	III
Small factories, shipping areas, machine shops, stadium common areas	II-VII
Large factories, fabrication shops	VII

* When placed in the paired room, the unit's noise should be relatively comparable to the ambient sound level.

Steam performance data

Table A: High motor speed

Standard conditions of 2 lb steam and 60 °F entering air

Model number	BTU/Hr	Sq. ft. EDR	Air data						
			Sound class*	Maximum mounting height (ft.)	Heat spread at max. height (ft.)	CFM	Outlet velocity	Final air temperature (°F)	Condensate lb/hr
Horizontal air delivery									
RH-18	18,000	75	II	9	17	400	510	102	18
RH-24	24,000	100	II	9	18	450	580	109	25
RH-33	33,000	138	II	10	20	630	510	109	35
RH-47	47,000	196	III	12	25	730	600	120	49
RH-63	63,000	263	III	14	29	1120	605	112	66
RH-86	86,000	358	III	15	31	1340	730	119	89
RH-108	108,000	450	III	15	32	1550	625	125	111
RH-121	121,000	504	III	16	33	1775	715	123	126
RH-165	165,000	688	IV	17	34	2500	750	121	170
RH-193	193,000	804	IV	18	37	2900	870	122	200
RH-258	258,000	1075	V	19	40	3900	920	121	267
RH-290	290,000	1208	V	20	44	4300	1010	122	300
RH-340	340,000	1417	V	20	46	5130	965	121	352
Vertical air delivery									
RV-42	42,000	175	II	11	17	950	779	103	43
RV-59	59,000	246	II	13	20	1150	943	111	61
RV-78	78,000	325	II	14	22	1550	992	110	81
RV-95	95,000	396	II	16	24	1775	1136	113	99
RV-139	139,000	579	III	18	27	2500	1284	116	144
RV-161	161,000	671	III	21	31	2900	1490	115	167
RV-193	193,000	804	IV	23	34	3900	1643	109	200
RV-212	212,000	883	IV	25	37	4300	1812	109	219
RV-247	247,000	1029	IV	26	39	5130	1805	107	256
RV-279	279,000	1163	V	30	45	5800	2040	107	288
RV-333	333,000	1388	V	30	45	6600	1968	110	345
RV-385	385,000	1604	VI	30	45	7860	1930	106	398
RV-500	500,000	2083	VI	37	56	10790	2490	103	518
RV-610	610,000	2542	VI	36	54	12350	2345	106	631

Table B: Reduced motor speed

Standard conditions of 2 lb steam and 60 °F entering air

Model number	BTU/Hr	Sq. ft. EDR	Air data						
			Sound class	Maximum mounting height (ft.)	Heat spread at max. height (ft.)	CFM	Outlet velocity	Final air temperature (°F)	Condensate lb/hr
Horizontal air delivery									
RH-18	14,800	62	I	9	12	310	395	104	15
RH-24	19,700	82	I	9	13	350	455	112	21
RH-33	27,100	113	I	10	14	490	395	111	29
RH-47	38,500	161	II	12	18	565	465	123	40
RH-63	51,700	216	II	14	21	870	470	115	54
RH-86	70,500	294	II	15	22	1040	570	123	73
RH-108	88,600	369	II	15	23	1240	500	126	91
RH-121	99,200	413	II	16	23	1415	570	125	103
RH-165	135,300	564	III	17	24	1990	600	123	139
RH-193	158,300	659	III	18	26	2310	695	123	164

Notes

- See page 4 for sound class definitions
- Data for horizontal air delivery units is based upon horizontal louvers open 30°
- Data for vertical air delivery units is based upon no deflectors installed, see page 10 for data on units with the addition of air outlet accessories

Hot water performance data

Table C: High motor speed

Standard conditions of 200 °F entering water, 60 °F entering air, and 20 °F water temperature drop

Model number	BTU/Hr	Water data			Air data							
		GPM	Pressure drop (ft. of water)	Min./max. GPM	Sound Class **	Maximum mounting height (ft.)*	Heat spread at maximum height	CFM	Outlet velocity	Final air temp. (°F)		
Horizontal air delivery												
RH-18	13,000	1.3	0.49	0.3/5.0	II	9	18	400	500	90		
RH-24	17,300	1.7	0.83	0.3/5.0	II	10	20	450	570	96		
RH-33	24,500	2.5	0.12	0.4/10.0	II	11	22	630	495	96		
RH-47	33,800	3.4	0.21	0.4/10.0	III	13	26	730	580	103		
RH-63	46,500	4.7	0.47	0.5/15.0	III	15	30	1120	590	98		
RH-86	61,900	6.2	0.79	0.5/15.0	III	16	31	1340	710	103		
RH-108	81,000	8.1	0.85	0.5/20.0	III	16	33	1550	605	108		
RH-121	90,000	9.0	1.04	0.7/20.0	III	17	36	1775	690	107		
RH-165	133,000	13.3	2.48	2.0/30.0	IV	18	38	2500	735	109		
RH-193	156,000	15.6	3.35	2.0/30.0	IV	19	40	2900	850	110		
RH-258	198,000	19.8	3.54	2.5/40.0	V	20	42	3900	895	107		
RH-290	224,000	22.4	4.45	2.5/40.0	V	21	46	4300	990	108		
RH-340	273,000	27.3	3.24	2.5/50.0	V	22	50	5130	945	109		
Vertical air delivery												
RV-42	30,500	3.1	0.09	0.5/10.0	II	11	15	17	11	950	776	91
RV-59	44,300	4.5	0.18	0.8/15.0	II	14	19	21	15	1150	940	97
RV-78	58,500	6.0	0.43	1.0/20.0	II	15	21	23	16	1550	990	96
RV-95	71,000	7.2	0.61	1.3/25.0	II	17	23	25	17	1775	1132	99
RV-139	111,000	11.3	0.84	1.0/30.0	III	18	25	28	19	2500	1281	103
RV-161	128,800	13.1	1.11	1.3/40.0	III	22	30	33	21	2900	1488	103
RV-193	142,700	14.5	0.81	1.5/50.0	IV	24	33	36	24	3900	1640	95
RV-212	159,000	16.1	0.98	2.0/60.0	IV	25	35	37	25	4300	1809	96
RV-247	197,000	19.9	1.65	2.0/60.0	IV	27	36	40	27	5130	1803	97
RV-279	220,000	22.2	2.01	2.3/75.0	V	31	39	47	31	5800	2037	97
RV-333	265,000	26.7	1.27	2.8/75.0	V	30	38	46	30	6600	1966	99
RV-385	308,000	31.1	1.68	3.3/75.0	VI	33	40	49	33	7860	1928	97
RV-500	403,000	40.9	2.32	3.0/100.0	VI	40	48	60	40	10790	2487	94
RV-610	459,000	46.3	2.42	6.0/100.0	VI	39	47	58	40	12350	2343	97

Table D: Reduced motor speed

Standard conditions of 200 °F entering water, 60 °F entering air, and 20 °F water

Model number	BTU/Hr	Water data			Air data					
		GPM	Pressure drop (ft. of water)	Min./max. GPM	Sound class**	Max. mounting height	Heat spread at max height*	CFM	Outlet velocity (FPM)	Final air temp. (°F)
Horizontal air delivery										
RH-18	10,660	1.3	0.49	0.2/5.0	I	9	13	310	390	92
RH-24	14,186	1.7	0.83	0.2/5.0	I	10	14	350	450	98
RH-33	20,090	2.5	0.12	0.6/10.0	I	11	16	490	390	98
RH-47	27,716	3.4	0.21	0.6/10.0	II	13	18	565	455	105
RH-63	38,130	4.7	0.47	0.6/15.0	II	15	21	870	460	101
RH-86	50,758	6.2	0.79	0.6/15.0	II	16	22	1040	550	105
RH-108	66,420	8.1	0.85	0.5/20.0	II	16	23	1240	485	110
RH-121	73,800	9.0	1.04	0.5/20.0	II	17	26	1415	555	108
RH-165	109,060	13.3	2.48	0.5/30.0	III	18	27	1990	590	111
RH-193	127,920	15.6	3.35	0.5/30.0	III	19	28	2310	680	111

Notes

- *Data for horizontal air delivery units is based upon horizontal louvers open 30°
- *Data for vertical air delivery units is based upon no deflectors installed, see page 10 for data on units with the addition of air outlet accessories
- **See page 4 for sound class definitions

Model identification and power code

- * Explosion proof motors are suitable for Class I, Div. 1 and Div. 2, Group C & D; Class II, Div. 1 and Div. 2, Groups F & G. The explosion proof units may not be used with a fluid temperature in excess of 329 °F and still maintain their explosion proof rating for National Electric Code ignition temperature rating T3B for grain dust. Class I, Group D Motors are for operations in areas containing gasoline, petroleum, naphtha, benzene, butane, propane, alcohol, acetone, lacquer solvent or natural gas. Class II, Group F motors are for operations in areas containing carbon black, coal or coke dust. Class II, Group G motors are for operations in areas containing flour, starch or grain dust. Class III motors are for operations in areas containing easily ignitable fibers and flyings.
- ** Three-phase motors require field supplied motor overload protection to be rated in compliance with the applicable installation code, as specified by the authority having jurisdiction.

Figure 1
Model number designation

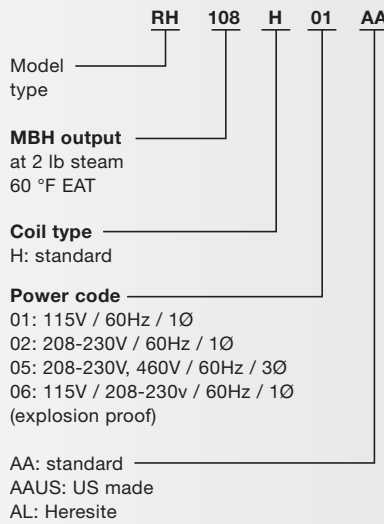

Figure 2
Serial number designation

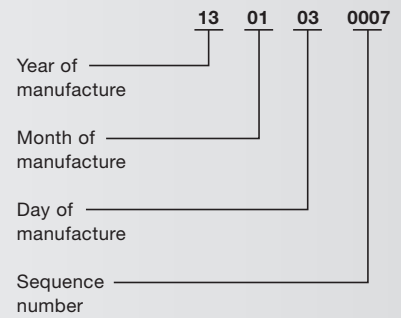

Table E: Motor data

Model number	Voltage, motor type and power code							
	115/60/1 and 208-230/60/1		115/60/1	208-230/60/1	230/460/60/3**	115/208-230/60/1*		
	Motor HP	Approximate RPM	Totally enclosed with thermal overload		Motor HP	Totally enclosed	Explosion proof motor HP	Explosion proof with thermal overload
			01 Amps	02 Amps		05 Amps		06 Amps
RH-18	1/30	1550	0.70	0.22	N/A	N/A	1/4	4.8/2.3-2.4
RH-24	1/30	1550	0.70	0.22	N/A	N/A	1/4	4.8/2.3-2.4
RH-33	1/15	1550	0.72	0.50	N/A	N/A	1/4	4.8/2.3-2.4
RH-47	1/15	1550	0.72	0.50	N/A	N/A	1/4	4.8/2.3-2.4
RH-63	1/10	1550	1.30	0.59	1/3	1.4/0.7	1/4	4.8/2.3-2.4
RH-86	1/10	1550	1.30	0.59	1/3	1.4/0.7	1/4	4.8/2.3-2.4
RH-108	1/8	1075	1.58	0.80	1/2	2.2/1.1	1/4	6.8/3.1-3.4
RH-121	1/8	1075	1.58	0.80	1/2	2.2/1.1	1/4	6.8/3.1-3.4
RH-165	1/4	1075	2.65	1.40	1/2	2.2/1.1	1/4	6.8/3.1-3.4
RH-193	1/4	1075	2.75	1.40	1/2	2.2/1.1	1/4	6.8/3.1-3.4
RH-258	1/3	1075	3.60	2.00	1/2	2.2/1.1	1/3	7.8/3.6-3.9
RH-290	1/2	1075	4.68	2.20	1/2	2.2/1.1	1/2	9.6/4.7-4.8
RH-340	1/2	1075	4.68	2.20	1/2	2.2/1.1	1/2	9.6/4.7-4.8
RV-42	1/10	1550	1.30	0.59	1/3	1.4/0.7	1/4	4.8/2.3-2.4
RV-59	1/10	1550	1.30	0.59	1/3	1.4/0.7	1/4	4.8/2.3-2.4
RV-78	1/6	1550	2.20	1.10	1/3	1.4/0.7	1/4	4.8/2.3-2.4
RV-95	1/6	1550	2.20	1.10	1/3	1.4/0.7	1/4	4.8/2.3-2.4
RV-139	1/4	1075	2.75	1.40	1/2	2.2/1.1	1/3	6.6/3.1-3.3
RV-161	1/4	1075	2.75	1.40	1/2	2.2/1.1	1/3	6.6/3.1-3.3
RV-193	1/2	900	4.68	2.20	1/2	2.2/1.1	1/2	9.6/4.7-4.8
RV-212	1/2	1075	4.68	2.20	1/2	2.2/1.1	1/2	9.6/4.7-4.8
RV-247	5/8	900	5.85	3.40	1	4.2/2.1	1/2	9.6/4.7-4.8
RV-279	5/8	1075	5.85	3.40	1	4.2/2.1	1/2	9.6/4.7-4.8
RV-333	1	1075	8.95	4.50	1	4.2/2.1	-	--
RV-385	-	-	--	--	1	4.2/2.1	-	--
RV-500	-	-	--	--	2	5.0/2.5	-	--
RV-610	-	-	--	--	2	6.8/3.4	-	--

Options, accessories, and control sequences

Control sequences

The following control sequence descriptions are commonplace for steam/hot water horizontal and vertical air delivery Rittling Unit Heaters.

Intermittent fan operation: intermittent hot/cold coil

When a thermostat calls for heat, the motor is energized. At the same time, a valve is opened allowing the heating fluid to enter the Rittling Unit Heater. Placing an aquastat to the supply or return piping will prevent motor operation until coil is properly heated to avoid the delivery of cold air. After thermostat is satisfied, the valve closes and motor is de-energized.

Intermittent fan operation: hot coil

When a thermostat calls for heat, the motor is energized. The heating fluid is continuously supplied to the Rittling Unit Heater, even with the motor off. After thermostat is satisfied, motor is de-energized.

Continuous fan operation: intermittent hot/cold coil

When a thermostat calls for heat, a valve opens, allowing the heating fluid to enter the unit heater. After the thermostat is satisfied, the valve closes. The fan runs continuously.

Factory mounted options

Option	Description
Disconnect	Unit mounted toggle switch for on/off control of fan operation.
Speed controller (variable speed)	Unit mounted speed controller allows infinite adjustment of fan speed, controlling airflow volume, available only with power code 01.
Unit mounted thermostat	Unit mounted thermostat turns fan on after air temperature falls below set point. Line voltage heating thermostat range 50 °F to 90 °F 25A at 120V/240V, only for power codes 01 and 02.
Manual starter	Unit mounted toggle switch starter with thermal overload protection for on/off fan control. Starter comes with a fused overload that protects unit up to 125% load, only for power code 01.
Diffuser blades	Diffuser blades are attached to louver to deflect airflow in directions left or right of the heater.

■ Contact factory for options requiring different voltages than listed above

Field installed options

Option	Description
Thermostat	Line voltage heating thermostat range 50 °F to 90 °F 25A at 120V/240V, only for power codes 01 and 02.
Explosion-proof thermostat	46 °F to 84 °F range 10.2A at 115V, 6.5A at 230V.
Aquastat	Surface mounted aquastat range 100 °F to 240 °F. It will delay the motor until a predetermined water temperature is reached.
Speed controller (variable speed)	Wall mounted speed controller allows remote infinite adjustment of fan speed, controlling airflow volume, available only with power code 01.
Thermostat guard	Clear plastic locking guard with lock and keys to deter unwanted adjustment of set temperature.
Pipe hanger kit	Allows unit to be suspended from ceiling by threaded pipe instead of threaded rod.
Manual starter	Wall mounted toggle switch starter with thermal overload protection for remote on/off control of fan. Starter comes with a thermal overload that protects unit up to 125% load, only for power code 01.
Disconnect	Wall mounted disconnect allows on/off control of fan operation.

■ Contact factory for options requiring different voltages than listed above

Options, accessories, and control sequences

Field installed options for vertical models

Option	Description
Cone-jet	The cone-jet allows the unit's discharged air to be adjusted from a direct high velocity stream to a broadened stream that can cover a larger area.
Truncone	The truncone allows for a broad air stream covering a larger area than possible with a cone-jet.
One-way louver	The one-way louver allows for a one directional discharge of air.
Two-way louver	The two-way louver allows for a bi-directional discharge of air.
3-cone anemostat	The 3-cone anemostat allows for an even air stream covering a larger area than possible with the truncone.
4-cone anemostat	The 4-cone anemostat allows for an even air stream covering a larger area than possible with the 3-cone anemostat.

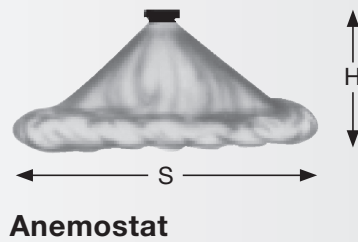
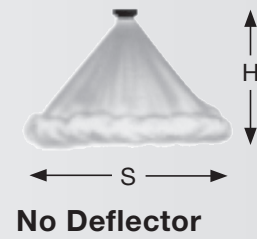
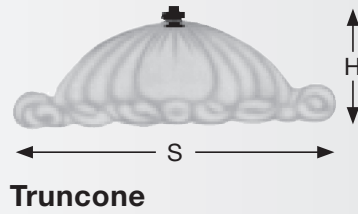
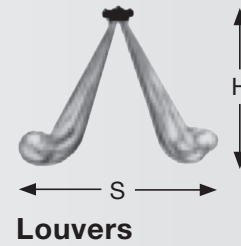
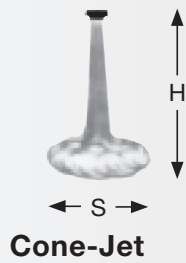

Vertical air outlet accessories

No deflector



Model number	Mounting maximums	
	Height	Spread
RV-42	11'	17'
RV-59	13'	20'
RV-78	14'	22'
RV-95	16'	24'
RV-139	18'	27'
RV-161	21'	31'
RV-193	23'	34'
RV-212	25'	37'
RV-247	26'	39'
RV-279	30'	45'
RV-333	30'	45'
RV-385	30'	45'
RV-500	37'	56'
RV-610	36'	54'

Cone jet

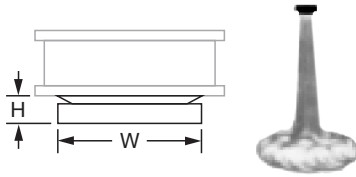

Model number	Accessory dimensions		Mounting maximums	
	Height	Width	Height	Spread
RV-42	6-1/2"	16-1/2"	15'	11'
RV-59			18'	13'
RV-78			19'	14'
RV-95	6-1/2"	18-1/2"	21'	16'
RV-139	8"	20-1/2"	24'	18'
RV-161			28'	21'
RV-193			31'	23'
RV-212	8"	22-1/2"	33'	25'
RV-247	9"	24-1/2"	34'	26'
RV-279			37'	30'
RV-333			37'	30'
RV-385	9"	26-1/2"	36'	30'
RV-500	10"	30-1/2"	44'	37'
RV-610			43'	36'

Truncone

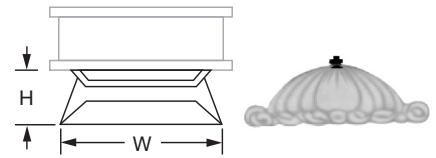

Model number	Accessory dimensions		Mounting maximums	
	Height	Width	Height	Spread
RV-42	10"	25"	8'	19'
RV-59			9'	25'
RV-78			11'	26'
RV-95	10"	25"	11'	26'
RV-139	12"	29"	13'	32'
RV-161			14'	35'
RV-193			16'	39'
RV-212	12"	29"	16'	39'
RV-247	14"	33"	17'	46'
RV-279			18'	53'
RV-333			17'	53'
RV-385	14"	33"	17'	53'
RV-500	18"	37"	19'	65'
RV-610	18"	39"	19'	63'

Louvers

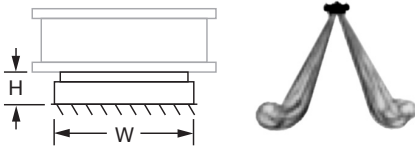

Model number	Accessory dimensions		Mounting maximums	
	Height	Width	Height	Spread
RV-42	6-1/2"	16-1/2"	13'	11'
RV-59			16'	14'
RV-78			17'	15'
RV-95	6-1/2"	18-1/2"	17'	15'
RV-139	8"	20-1/2"	21'	18'
RV-161			23'	20'
RV-193			25'	22'
RV-212	8"	22-1/2"	25'	22'
RV-247	9"	24-1/2"	30'	26'
RV-279			35'	30'
RV-333			35'	30'
RV-385	9"	26-1/2"	35'	30'
RV-500	10"	30-1/2"	42'	37'
RV-610			41'	41'

3-cone anemostat

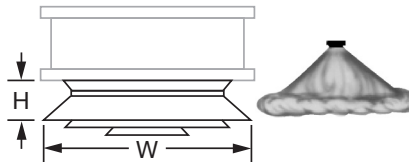

Model number	Accessory dimensions		Mounting maximums	
	Height	Width	Height	Spread
RV-42	G/2"	22-1/2"	8'	22'
RV-59			9'	28'
RV-78			11'	30'
RV-95	G/2"	24-1/2"	11'	30'
RV-139	14"	26-1/2"	13'	36'
RV-161			14'	40'
RV-193			16'	44'
RV-212	14"	28-1/2"	16'	44'
RV-247	15"	30-1/2"	17'	52'
RV-279			18'	60'
RV-333			17'	60'
RV-385	15"	32-1/2"	17'	60'
RV-500	16"	36-1/2"	19'	74'
RV-610	16"	38-1/2"	—	—

4-cone anemostat

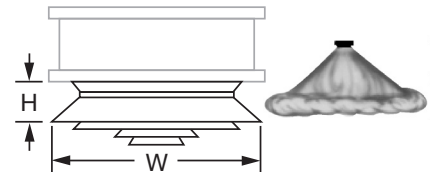

Model number	Accessory dimensions		Mounting maximums	
	Height	Width	Height	Spread
RV-42	14"	25"	8'	28'
RV-59			8'	35'
RV-78			8'	30'
RV-95	14"	27"	8'	30'
RV-139	1/2"	29"	9'	45'
RV-161			10'	50'
RV-193			12'	55'
RV-212	1/2"	31"	12'	55'
RV-247	16-1/2"	33"	13'	65'
RV-279			13'	75'
RV-333			13'	75'
RV-385	16-1/2"	35"	13'	75'
RV-500	1A/2"	39"	13'	93'
RV-610	1A/2"	41"	—	—

Table F: Hot water mounting height correction factors

Entering water temperature	140	150	160	170	180	190	200	210	220	230	240	250	260	270	280	290	300
Correction factor	1.33	1.25	1.19	1.13	1.08	1.04	1.00	0.97	0.94	0.91	0.89	0.86	0.84	0.82	0.80	0.78	0.77

Notes:

- Data shown for standard 2lb steam and 60 °F EWT conditions. For louvers or cone jet, data shown for deflectors in fully-opened position.
- For mounting height and spread for hot water, multiply the value above by 1.06 to approximate the mounting height and spread at 200 °F EWT.
- For entering water temperature other than 200 °F, multiply the value above by 1.06 and then multiply by the correction factor in Table F.

Dimensions and data

RH models

RH-18 through RH-86

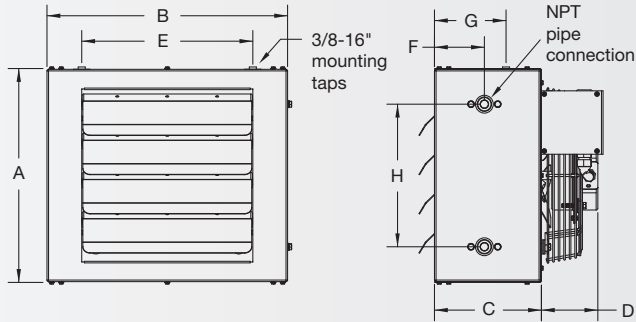

RH-108 through RH-340

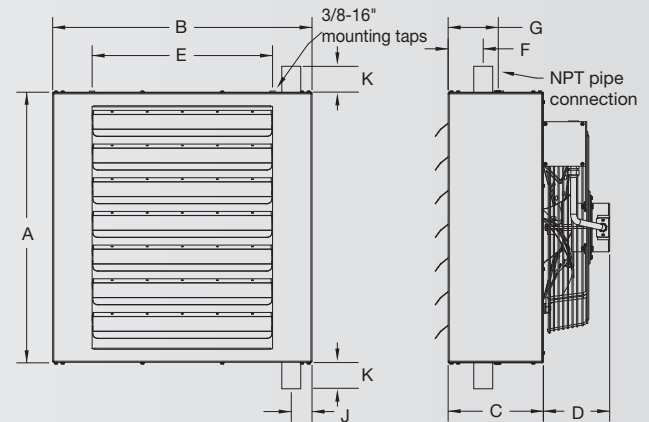

Dimensional data

Model	A	B	C	D	E	F	G	H	J	K	NPT connections	Fan diameter	Approximate shipping weight (lb)
RH-18	15	16-7/8	7-1/2	4-1/2	12	3-1/2	5	10	-	-	3/4	9	37
RH-24	15	16-7/8	7-1/2	4-1/2	12	3-1/2	5	10	-	-	3/4	9	39
RH-33	19	19-3/4	7-1/2	4-3/4	12	3-1/2	5	14	-	-	3/4	12	48
RH-47	19	19-3/4	7-1/2	4-3/4	12	3-1/2	5	14	-	-	3/4	12	50
RH-63	19	25-3/4	8-1/2	4-3/4	18	3-1/2	5	14	-	-	3/4	14	61
RH-86	19	25-3/4	8-1/2	4-3/4	18	3-1/2	5	14	-	-	3/4	14	63
RH-108	27	25-7/8	9-1/2	6-1/4	18	3-1/2	5-1/4	-	2	3	1-1/2	18	88
RH-121	27	25-7/8	9-1/2	6-1/4	18	3-1/2	5-1/4	-	2	3	1-1/2	18	90
RH-165	27	31-7/8	10	6-1/4	24-7/8	3-1/2	6-1/4	-	2	3	1-1/2	20	110
RH-193	27	31-7/8	10	8-3/8	24-7/8	3-1/2	6-1/4	-	2	3	1-1/2	20	115
RH-258	33	40-13/16	11	8-3/8	32-7/8	3-1/2	6-1/4	-	2-1/4	3	2	22	162
RH-290	33	40-13/16	11	8-3/8	32-7/8	3-1/2	6-1/4	-	2-1/4	3	2	22	164
RH-340	39	40-13/16	12	8-3/8	32-7/8	3-1/2	7-1/4	-	2-1/4	3	2	24	210

Note:

- Dimensions in inches unless otherwise noted

Maximum mounting height

Model	200 °F EWT and 60 °F EAT		2 lb steam and 60 °F EAT	
	Height	Spread	Height	Spread
RH-18	9'	18'	9'	17'
RH-24	10'	20'	9'	18'
RH-33	11'	22'	10'	20'
RH-47	13'	26'	12'	25'
RH-63	15'	30'	14'	29'
RH-86	16'	31'	15'	31'
RH-108	16'	33'	15'	32'
RH-121	17'	36'	16'	33'
RH-165	18'	38'	17'	34'
RH-193	19'	40'	18'	37'
RH-258	20'	42'	19'	40'
RH-290	21'	46'	20'	44'
RH-340	22'	50'	20'	46'

Notes:

- All dimensions in inches
- RH-18 through RH-86 have side female NPT pipe connections
- RH-108 through RH-340 have top and bottom male NPT pipe connections
- Units should be mounted a minimum of 5" from wall

Dimensions and data

RH models with explosion proof motor

RH-18 through RH-86

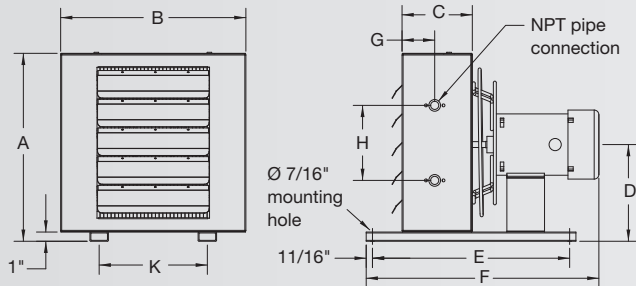

RH-108 through RH-340

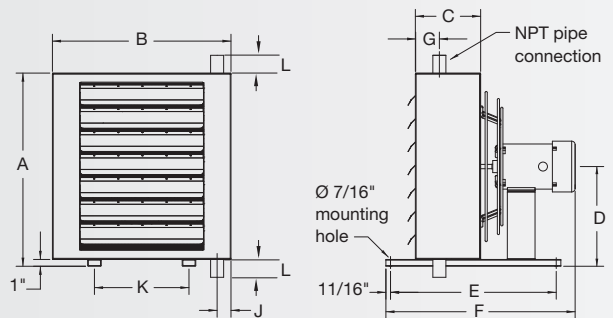

Dimensional data

Model	A	B	C	D	E	F	G	H	J	K	L	NPT connections	Fan diameter	Approximate shipping weight (lb)
RH-18	16	16-7/8	7-1/2	8-1/2	21-1/2	24-7/8	3-1/2	10	-	13-1/8	-	3/4	9	64
RH-24	16	16-7/8	7-1/2	8-1/2	21-1/2	24-7/8	3-1/2	10	-	13-1/8	-	3/4	9	66
RH-33	20	19-3/4	7-1/2	10-1/2	21-1/2	24-7/8	3-1/2	14	-	11-7/8	-	3/4	12	75
RH-47	20	19-3/4	7-1/2	10-1/2	21-1/2	24-7/8	3-1/2	14	-	11-7/8	-	3/4	12	77
RH-63	20	25-3/4	8-1/2	10-1/2	22-11/16	25-3/4	3-1/2	14	-	15-7/16	-	3/4	14	88
RH-86	20	25-3/4	8-1/2	10-1/2	22-11/16	25-3/4	3-1/2	14	-	15-7/16	-	3/4	14	90
RH-108	28	25-7/8	9-1/2	14-1/2	23-7/16	27-7/16	3-1/2	-	2	14	3	1-1/2	18	118
RH-121	28	25-7/8	9-1/2	14-1/2	23-7/16	27-7/16	3-1/2	-	2	14	3	1-1/2	18	120
RH-165	28	31-7/8	10	14-1/2	24-5/8	28-7/16	3-1/2	-	2	20-1/16	3	1-1/2	20	140
RH-193	28	31-7/8	10	14-1/2	24-5/8	28-7/16	3-1/2	-	2	20-1/16	3	1-1/2	20	145
RH-258	34	40-13/16	11	17-1/2	26-5/8	29-11/16	3-1/2	-	2-1/4	23-9/16	3	2	22	195
RH-290	34	40-13/16	11	17-1/2	26-5/8	29-11/16	3-1/2	-	2-1/4	23-9/16	3	2	22	205
RH-340	40	40-13/16	12	20-1/2	28-3/16	31-3/16	3-1/2	-	2-1/4	27	3	2	24	251

Note:

- Dimensions in inches unless otherwise noted

Maximum mounting height

Model	200 °F EWT and 60 °F EAT		2 lb steam and 60 °F EAT	
	Height	Spread	Height	Spread
RH-18	9'	18'	9'	17'
RH-24	10'	20'	9'	18'
RH-33	11'	22'	10'	20'
RH-47	13'	26'	12'	25'
RH-63	15'	30'	14'	29'
RH-86	16'	31'	15'	31'
RH-108	16'	33'	15'	32'
RH-121	17'	36'	16'	33'
RH-165	18'	38'	17'	34'
RH-193	19'	40'	18'	37'
RH-258	20'	42'	19'	40'
RH-290	21'	46'	20'	44'
RH-340	22'	50'	20'	46'

Notes:

- All dimensions in inches
- RH-18 through RH-86 have side female NPT pipe connections
- RH-108 through RH-340 have top and bottom male NPT pipe connections
- Units should be mounted a minimum of 5" from wall

Dimensions and data

Model RV

RV-42, RV-59

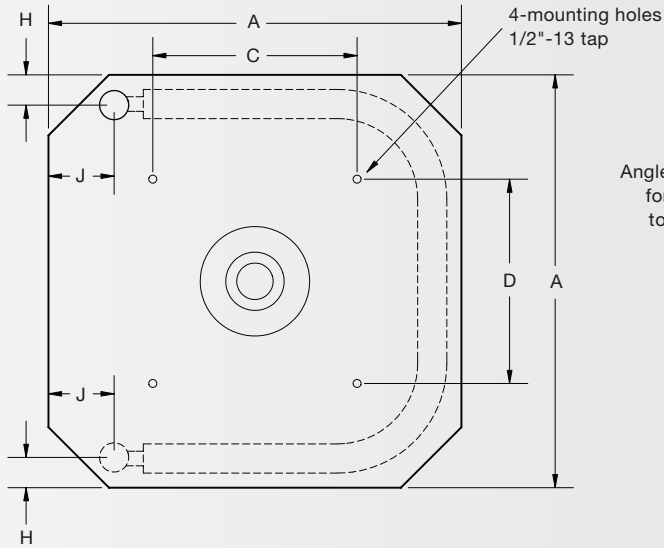

RV-78 through RV-610

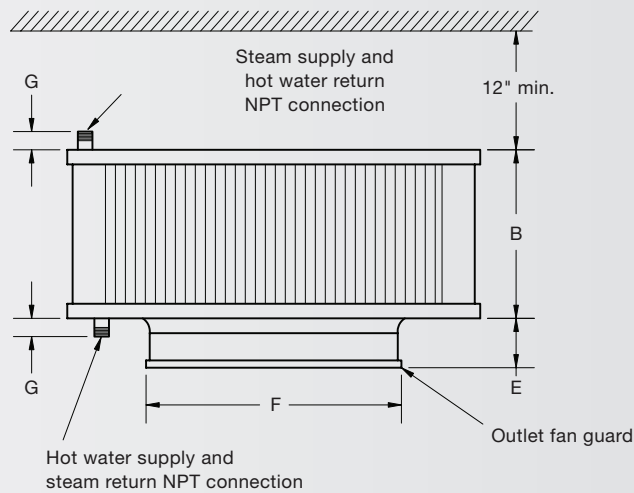
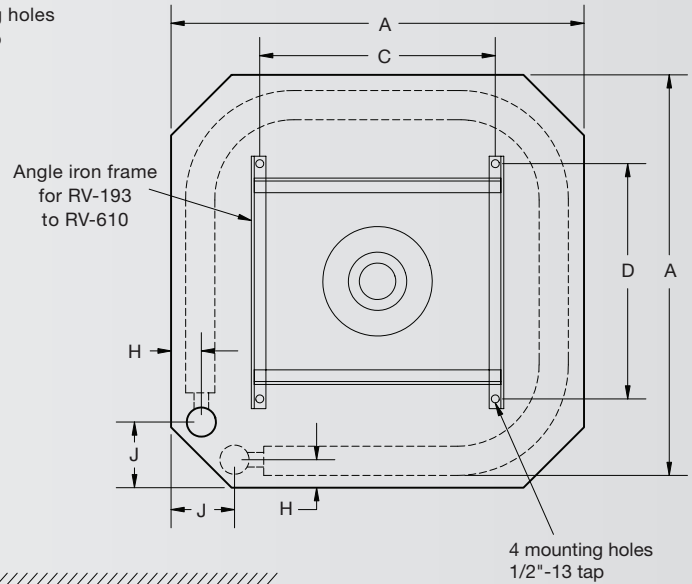

Dimensional data

Model	A	B	C	D	E	F	G	H	J	Male NPT connections	Fan diameter	Approx. shipping weight lb
RV-42/RV-59	23	6-3/8	12	12	3-1/8	15	2-3/4	1-7/8	3-1/4	1-1/2	13-3/4	65
RV-78/RV-95	25	6-3/8	13	13	3-1/8	17	2-3/4	1-7/8	3-1/4	1-1/2	15-3/4	76
RV-139/RV-161	25	10-3/8	14-7/16	14-7/16	3-1/8	18-7/8	2-3/4	2	3-1.4	1-1/2	17-3/4	118
RV-193/RV-212	30	12-3/8	19	17	4	20-7/8	2-3/4	2	3-5/8	2	19-3/4	157
RV-247/RV-279	35	12-3/8	20	18	4	22-7/8	2-3/4	2	3-5/8	2	21-3/4	185
RV-333/RV-385	35	18-3/8	21	21	4	24-3/4	2-3/4	2-1/2	4-1/2	2-1/2	23-3/4	220
RV-500	43	18-3/8	14	14	4	28-3/4	2-3/4	2-1/2	4-1/2	2-1/2	27-3/4	285
RV-610	43	18-3/8	14	14	4	30-3/4	2-3/4	2-1/2	4-1/2	2-1/2	29-3/4	331

Notes:

- All dimensions in inches
- RH-18 through RH-86 have side female NPT pipe connections
- RH-108 through RH-340 have top and bottom male NPT pipe connections
- Units should be mounted a minimum of 5" from wall

Mechanical specifications

General

Furnish and install Rittling Unit Heaters where indicated on the plans and in the specifications, with required mounting components and accessories. All units shall be capable of meeting or exceeding the scheduled capacities for heating and air delivery. Units shall be ETL certified for the United States and Canada in compliance with UL/ANSI Standard 1995 and CSA C22.2 No. 236-95.

Construction

All units shall have panels fabricated of not less than 18-gauge cold rolled steel and consist of top/back and side halves. Both halves are joined on top and back with hex head screws. Top casing is furnished with threaded hanger connections for suspension of unit. Fan venture is die-formed on back half.

Casing on all vertical units are top and bottom pieces joined by corners and additional hardware. Top casing is furnished with threaded hanger connections for suspension of unit.

Units shall be equipped with horizontal, individually adjustable louvers (RH). [Vertical louvers for four-way air control shall be included (RH).]

- Option: Provide a [cone-jet] [truncone] [one-way louver] [two-way louver] [3-cone anemostat] [4-cone anemostat] to provide specific air throw pattern on vertical Rittling Unit Heater.
- Option: Provide a pipe hanging kit that allows the unit to be hung from threaded pipe in lieu of threaded hanger rod.

Painted finish

All painted cabinet exterior panels shall be finished with a standard textured gray epoxy powder coat paint.

Power

Units shall not exceed scheduled power consumption.

Motor

Motors shall be two speed, permanent split-capacitor, totally enclosed, permanently lubricated bearing type with automatic reset integral thermal overload protection (3-phase motors require field supplied motor overload protection), designed to handle up to 104°F maximum constant ambient temperature.

Shaded pole motors are not acceptable. Single speed motors are not acceptable.

[Explosion proof motors have an enclosure designed and constructed to withstand an explosion of a specified gas or vapor which may occur within the motor and to prevent the ignition of this gas or vapor surrounding the unit. Explosion proof motor is suitable for Class I, Div I&II, Groups C&D and Class II, Div I&II, Groups F&G. The explosion proof motors may not be used with a fluid temperature in excess of 329°F and still maintain the explosion proof rating for NEC ignition temperature rating T3B for grain dust. All explosion proof motors are shelf mounted.

- Option: Provide a solid state variable speed controller.

Fan

Fans shall have non-conducting, spark-proof aluminum blades, with a steel hub. Each fan blade is balanced and designed specifically for the unit in which it is installed to assure maximum air delivery and quiet operation.

Fan guard

Fan guard shall be finger-proof, constructed of welded steel rod and finished with a standard black epoxy powder coat paint. Units mounted below 8 feet from the floor must be equipped with an OSHA fan guard to meet ETL and OSHA requirements.

Coils

Heating coil is designed for either two-pipe steam or hot water heating system. Coils shall have ½" nominal diameter seamless copper tubes and shall be mechanically expanded to provide an efficient, permanent bond between the tube and integral collar of the aluminum fin. Minimum copper tube thickness shall be 0.028".

Fins shall be die-formed and have a high efficiency aluminum surface optimized for heat transfer, air pressure drop and carryover. Minimum fin thickness shall be 0.010". Lanced fins shall not be acceptable. Fins are continuous across width and depth of coil and are vertically oriented to resist collection of dirt and foreign particles.

Mechanical specifications

Coils are of non-ferrous construction and serpentine design for RH-18 and RH-24. All other units incorporate brazed steel header tubes. RH-18 through RH-86 units have ¾" female threaded NPT, brass header connections while all other units have male threaded NPT connections.

All coils shall be tested at 275 PSIG air pressure under water, and rated for a maximum 220 PSIG water or 150 PSIG steam and 375°F. Coils have CRN pressure vessel certification for Ontario and Quebec provinces.

Electrical

Units shall be furnished with single point power connection. Provide an electrical junction box for motor and other electrical terminations.

- Option: Provide an explosion proof wall thermostat, shipped loose for remote mounting.
- Option: Provide a line voltage wall thermostat, shipped loose for remote mounting. Adjustable setpoint dial included.
- Option: Provide a clear, plastic locking thermostat guard, shipped loose for remote mounting.
- Option: Provide a service disconnect switch to isolate power from the unit during maintenance.
- Option: Provide a manual motor starter to provide overload protection for the motor.
- Option: Provide a line voltage aquastat, shipped loose for remote mounting on the incoming supply piping. Adjustable setpoint dial included.

Warranty

Zehnder Rittling guarantees its products to be free from defects in material and workmanship for a period of two years from date of shipment from our factory.

Should there be any defects in the good(s), the purchaser should promptly notify Zehnder Rittling. Upon receipt of written consent from Zehnder Rittling, the purchaser shall return the defective good(s) to the factory for inspection with freight prepaid. If inspection shows the goods to be defective, Zehnder Rittling will at its discretion repair or replace the said item(s).

Defects arising from damage due to shipment, improper installation, negligence or misuse by others are not covered by this warranty.

This warranty is extended only to the original purchaser from Zehnder Rittling.

IMPORTANT: Approved submittal documentation, specific to each project, supersedes the general guidelines contained within this document.

© Zehnder July 2016, English, subject to change without notice