

# Rittling Cabinet Unit Heater

Installation, Operations and Maintenance





Zehnder decorative radiators



Heating and cooling ceiling systems

**zehnder**

always the  
best climate



Comfortable indoor ventilation



Clean air solutions

Always the best climate for

# IMPROVED QUALITY OF LIFE

With Zehnder, you will find the perfect climate for any space.

[www.zehnder-systems.com](http://www.zehnder-systems.com)

---

**IMPORTANT:** Submittal documentation, specific to each project, supersedes the general guidelines contained within this manual.

<b>Models and arrangements</b>	<b>2</b>
<b>Ratings</b>	<b>4</b>
<b>Dimensions and data</b>	<b>6</b>
<b>General information</b>	<b>13</b>
<b>Receiving</b>	<b>13</b>
<b>Safety considerations</b>	<b>14</b>
<b>Unpacking and preparation</b>	<b>15</b>
<b>Handling and installation</b>	<b>16</b>
<b>Hot water connections</b>	<b>17</b>
<b>Ductwork connections</b>	<b>18</b>
<b>Electrical connections</b>	<b>19</b>
<b>Wiring diagram</b>	<b>20</b>
<b>Start-up</b>	<b>22</b>
<b>Air system balancing</b>	<b>23</b>
<b>Heating system</b>	<b>23</b>
<b>Water system balancing</b>	<b>24</b>
<b>Water treatment</b>	<b>24</b>
<b>Controls operation</b>	<b>25</b>
<b>Exposed unit touch-up</b>	<b>25</b>
<b>Normal operation/maintenance</b>	<b>26</b>
<b>Replacement parts</b>	<b>28</b>
<b>Equipment start-up checklist</b>	<b>28</b>
<b>Warranty</b>	<b>30</b>

# Models and airflow arrangements

## Wall models



**RW: Wall**  
RW-260 shown  
RW-270 and RW-280 available

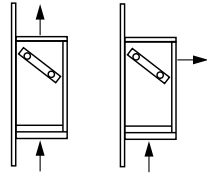

**RW-260 RW-270**

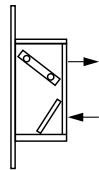

**RW-280**



**RRWI: Wall, partially recessed, inverted flow**  
RRWI-330 shown

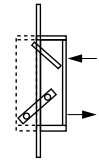

**RRWI-330**



**RWI: Wall, inverted flow**  
RWI-290 shown  
RWI-300 and RWI-310 available

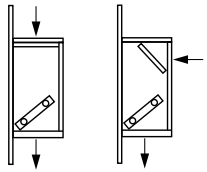

**RWI-290 RWI-300**

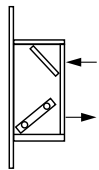

**RWI-310**



**RFRW: Wall, fully recessed**  
RFRW-340 shown

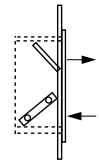

**RFRW-340**



**RRW: Wall, partially recessed**  
RRW-320 shown

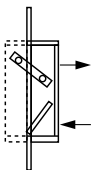

**RRW-320**



**RFRWI: Wall, fully recessed, inverted flow**  
RFRWI-350 shown

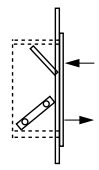

**RFRWI-350**

# Models and airflow arrangements

## Floor models



### RF: Floor

RF-200 shown, RF-220 available

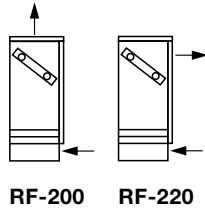

### RFI: Floor, inverted flow

RFI-240 shown, RFI-250 available

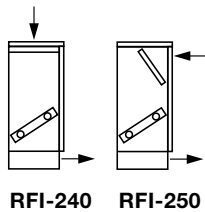

### RS: Floor, sloped

RS-200 shown

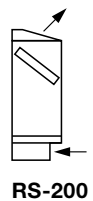

### RSI: Floor, sloped, inverted flow

RSI-240 shown

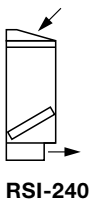

## Ceiling models



### RC: Ceiling

RC-360 shown  
RC-370, RC-380, RC-390 and  
RC-400 available

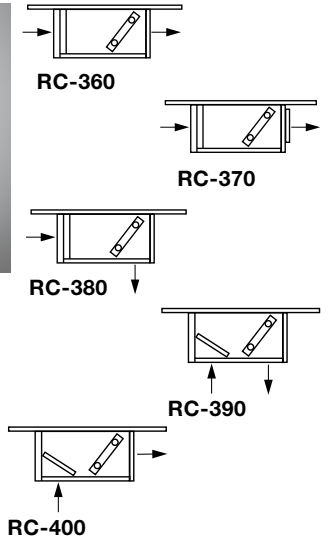

### RRC: Ceiling, partially recessed

RRC-440 shown

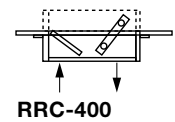

### RFRC: Ceiling, fully recessed

RFRC-420 shown

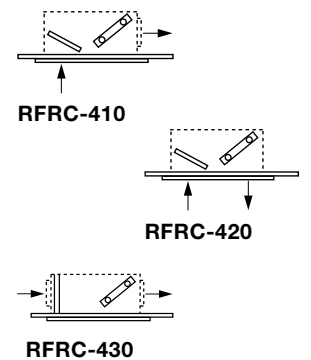

# Standard ratings and specifications

**Table A**

Specifications		02	03	04	06	08	10	12
Steam capacity	MBH	18.7	25.5	34.8	51.0	62.8	73.4	90.7
	EDR	76	104	144	212	260	304	376
Hot water capacity (1 row coil)	MBH	16.2	22.4	30.7	45.5	54.8	64.5	80.1
	GPM	1.7	2.3	3.2	4.8	5.7	6.7	8.4
	WPD	0.2	0.4	0.8	2.2	0.5	0.7	1.2
Hot water capacity (2 row coil)	MBH	25.0	34.3	47.2	69.5	86.6	101.2	125.8
	GPM	2.6	3.6	4.9	7.3	9.0	10.5	13.1
	WPD	0.8	1.7	3.6	9.3	2.2	3.3	5.6
Heating capacity (3 row main coil)	MBH	21.7	30.1	40.8	60.4	75.5	88.1	108.2
	GPM	1.5	2.1	2.8	4.1	5.2	6.0	7.4
	WPD	0.5	1.1	2.2	5.5	9.0	13.2	21.4
Heating capacity (4 row main coil)	MBH	19.9	25.5	46.3	65.8	87.0	100.7	119.9
	GPM	1.9	2.5	4.3	5.8	7.5	10.3	12.3
	WPD	6.2	11.8	35.8	15.2	26.1	19.6	28.4
CFM: standard PSC	High	220	300	420	620	810	940	1180
	Medium	150	200	310	450	600	720	875
	Low	125	140	220	350	440	480	660
CFM: high static PSC (@ 0.2" ESP)	High	250	345	490	640	920	1020	1150
	Medium	210	290	425	550	780	870	980
	Low	160	230	320	420	590	660	750
1/2 Row Coil	FPI	12	12	12	12	12	12	12
	Face area, ft2	1.25	1.67	2.08	2.92	3.33	3.89	4.58
	Coil connections	1/2" Cu	1/2" Cu	1/2" Cu	1/2" Cu	1/2" Cu	1/2" Cu	1/2" Cu
Blower	Quantity	1	1	2	2	1, 2	4	4
	Diameter	5.7"	5.7"	5.7"	5.7"	5.7"	5.7"	5.7"
	Width	7.5"	10.4"	7.5"	10.4"	7.5", 10.4"	7.5"	10.4"
Filter	Number	1	1	1	1	1	1	1
	Length, in.	22	28	34	46	52	60	70
	Width, in. - standard	9.75	9.75	9.75	9.75	9.75	9.75	9.75
	Width, in. - floor with inlet grille	7.25	7.25	7.25	7.25	7.25	7.25	7.25
	Rating	Merv 4	Merv 4	Merv 4	Merv 4	Merv 4	Merv 4	Merv 4
Thickness, in.	1	1	1	1	1	1	1	
Cabinet size	Length, in.	38.2	44.2	50.2	62.2	68.2	76.2	86.2
	Width, in.	10	10	10	10	10	10	10
	Height, in. - wall/ceiling	24	24	24	24	24	24	24
	Height, in. - flat top floor	26.5	26.5	26.5	26.5	26.5	26.5	26.5
	Height, in. - slope top floor	29.25	29.25	29.25	29.25	29.25	29.25	29.25
Shipping weight, lbs.		85	100	115	140	155	170	195

**Notes**

- Airflows for floor mounted units with 1-row coil. Please check with factory for adjusted outputs on other models
- Heating capacity based on inlet air 60 °F DB, 200°F entering water or 2 psig steam, 180°F leaving water, standard motor at high fan speed
- Pressure drop (PD) shown in feet of water
- Overall length for fully and partially recessed units is length +3", adding in the trim kit. Wall rough-in hole dimension to be length +1/2" by 24-1/2" minimum. Maximum opening to be length by +2" by 26".



# Electrical data

**Table B**

	Motor Type		02	03	04	06	08	10	12
HP	PSC	Standard	1/30	1/30	1/25	1/15	1/30, 1/15	(2) 1/15	(2) 1/15
		High-Static	1/12	1/12	1/10	1/7	1/12, 1/7	(2) 1/7	(2) 1/7
	ECM	Standard	1/4	1/4	1/4	1/4	(2) 1/4	(2) 1/4	(2) 1/4
		High-Static	1/4	1/4	1/4	1/4	(2) 1/4	(2) 1/4	(2) 1/4
Motor FLA 120V	PSC	Standard	0.60	0.60	0.68	1.13	1.73	2.26	2.26
		High-Static	1.05	1.05	1.2	1.7	2.8	3.4	3.4
	ECM	Standard	0.92	0.84	1.12	1.70	2.85	3.04	3.58
		High-Static	1.05	1.05	1.2	1.7	2.8	3.4	3.4
Power Input: Watts 120V	PSC	Standard	57	61	75	130	200	240	250
		High-Static	117	120	130	180	325	368	368
	ECM	Standard	38	38	45	80	125	147	157
		High-Static	117	120	130	180	325	368	368
Motor FLA 120V/60Hz/1Ph	ECM	Standard	0.78	0.88	1.05	1.60	2.52	2.65	3.20
		High static	1.33	1.33	1.80	2.21	3.16	3.47	3.60
Power input: watts 120V/60Hz/1Ph	ECM	Standard	36	43	46	79	123	152	158
		High static	88	90	129	151	240	293	302

**Notes:**

- Maximum circuit ampacity (MCA) =  
1.25 x (FLA motor 1 + FLA motor 2 + FLA electric heat)
- Maximum overcurrent protection (MOP) =  
(2.25 x FLA motor 1) + FLA motor 2 + FLA electric heat
- If the calculated MOP is within 10% of the next smaller available fuse size, that fuse size shall be used. If not, the next larger fuse size above the calculated MOP must be used.
- If the selected MOP is smaller than the MCA, the selected MOP must be increased to the next larger available fuse size above the MCA.
- If the MOP is less than 15, it shall be rounded up to 15 amps. This is the minimum fuse or circuit breaker permitted by code.
- EC motor nameplate amperage indicates the motor hardware peak amperage while the motor full load amperage (FLA) is limited by the motor's factory programmed operating range, programmed specifically for each unit size. The programmed operating range is generally only a portion of the motor hardware full potential resulting in the motor FLA being lower than the nameplate FLA. Motor FLA will be reflected on the Cabinet Unit Heater serial tag and should be used when sizing building electrical requirements.

# Dimensions and data

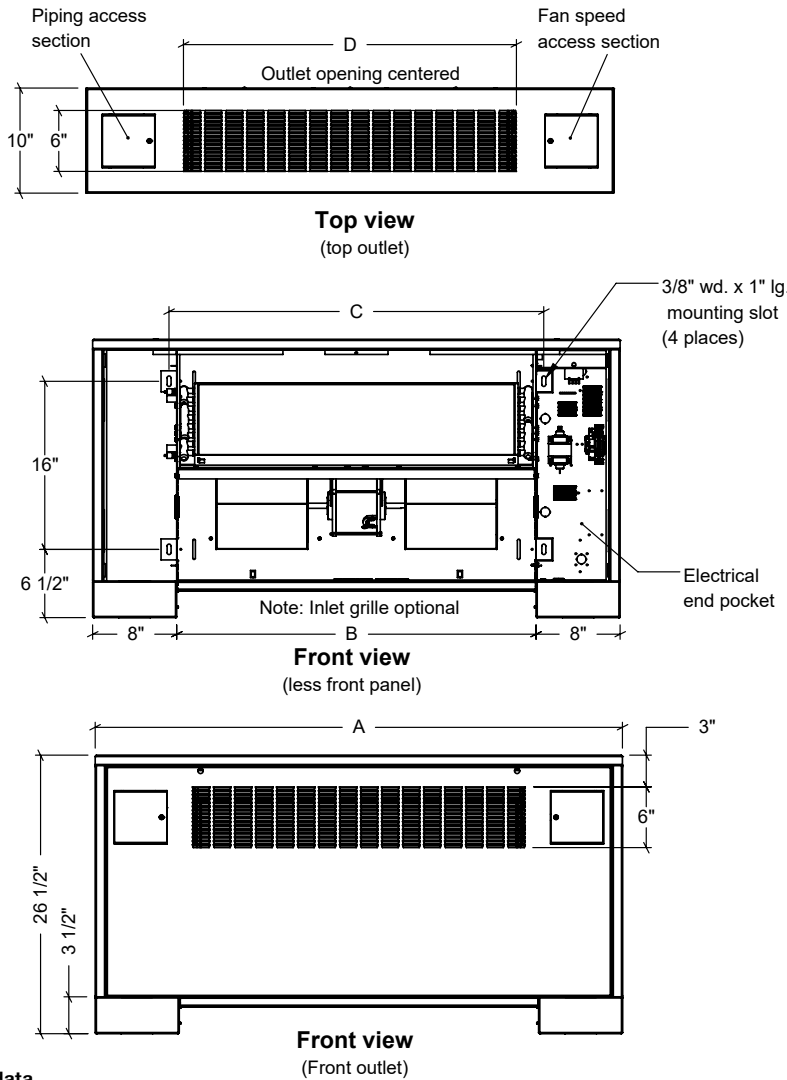

## Models RF and RFI

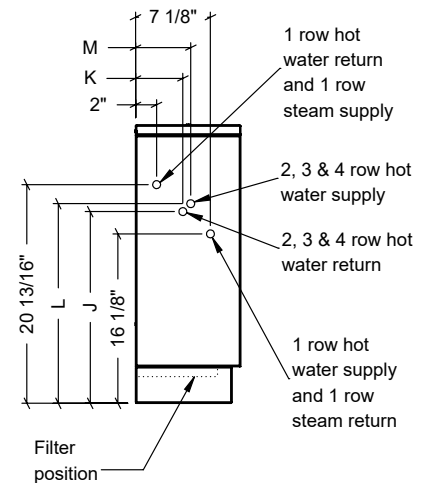
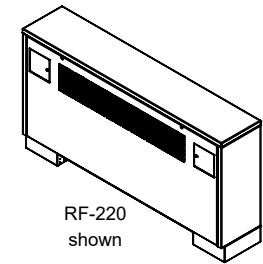
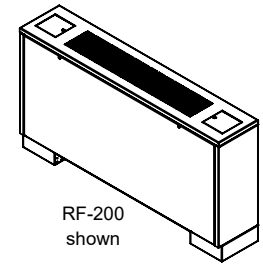

Side view: Model RF

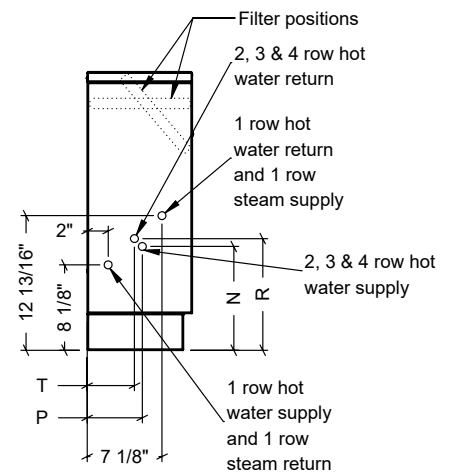

Side view: Model RFI

### Dimensional data

Unit size	A			B	C	D
	Std.	6" Ext.	6" Ext. x2			
02	38-3/16	44-3/16	50-3/16	22-3/16	24	20
03	44-3/16	50-3/16	56-3/16	28-3/16	30	26
04	50-3/16	56-3/16	62-3/16	34-3/16	36	32
06	62-3/16	68-3/16	74-3/16	46-3/16	48	44
08	68-3/16	74-3/16	80-3/16	52-3/16	54	50
10	76-3/16	82-3/16	88-3/16	60-3/16	62	58
12	86-3/16	92-3/16	98-3/16	70-3/16	72	68

Coil	J	K	L	M	N	P	R	T
2 Row	18-1/4	4-7/16	19-1/16	5-3/16	9-7/8	5-3/16	10-11/16	4-7/16
3 Row	19-1/16	3-1/16	20-3/8	4-13/16	8-9/16	4-13/16	9-7/8	3-1/16
4 Row	19-1/16	3-1/16	20-3/8	4-13/16	8-9/16	4-13/16	9-7/8	3-1/16

### Notes:

- 1 and 2 row coil supply and return 1/2" nominal (5/8" OD) all sizes
- Inlet grille optional
- Unit shown with left hand piping connections and right hand electrical connections as standard
- Right hand piping connections with left hand electrical connections available as an option
- Piping hand determined when facing the air outlet
- All listed dimensions are approximate and are subject to change without notice
- Modifications to the product specifications must be accepted by Zehnder Rittling at its base office
- See [www.zehnder-rittling.com](http://www.zehnder-rittling.com) for any recent updates or changes



# Dimensions and data

## Models RS and RSI

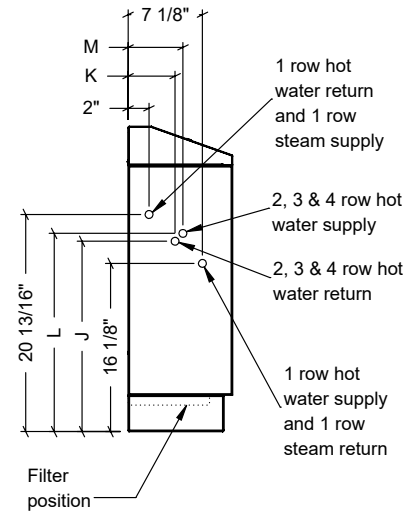
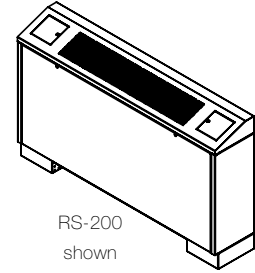
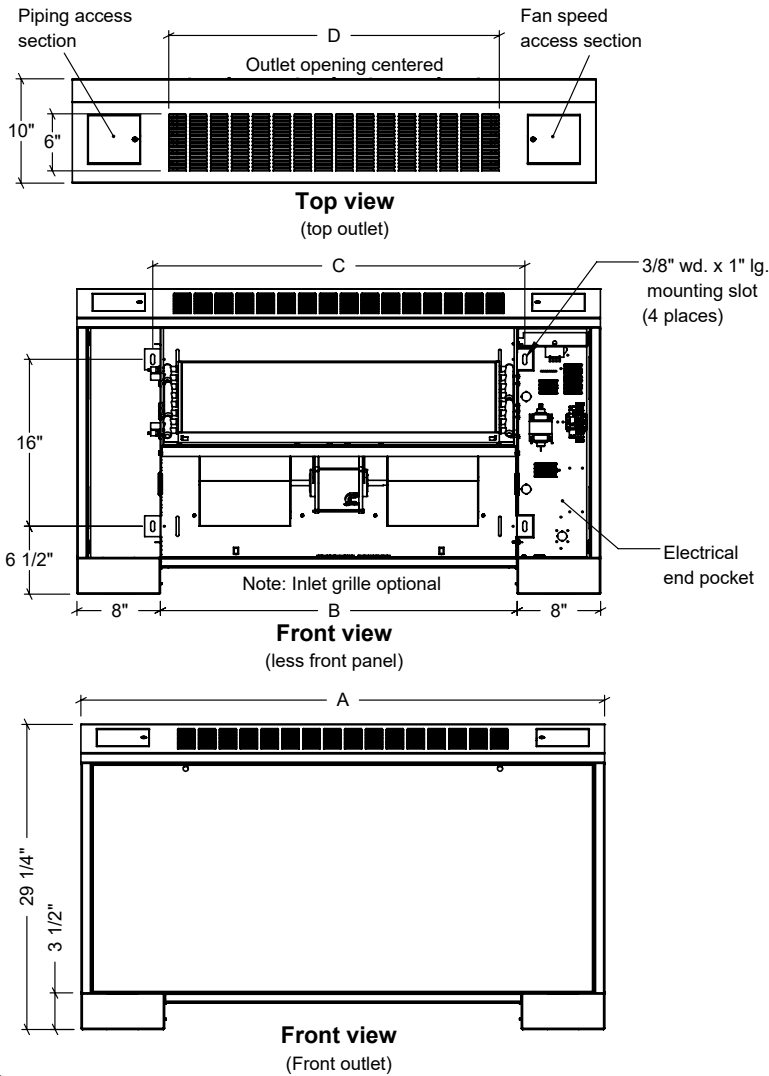

**Side view: Model RS**

### Dimensional data

Unit size	A			B	C	D
	Std.	6" Ext.	6" Ext. x2			
02	38-3/16	44-3/16	50-3/16	22-3/16	24	20
03	44-3/16	50-3/16	56-3/16	28-3/16	30	26
04	50-3/16	56-3/16	62-3/16	34-3/16	36	32
06	62-3/16	68-3/16	74-3/16	46-3/16	48	44
08	68-3/16	74-3/16	80-3/16	52-3/16	54	50
10	76-3/16	82-3/16	88-3/16	60-3/16	62	58
12	86-3/16	92-3/16	98-3/16	70-3/16	72	68

Coil	J	K	L	M	N	P	R	T
2 Row	18-1/4	4-7/16	19-1/16	5-3/16	9-7/8	5-3/16	10-11/16	4-7/16
3 Row	19-1/16	3-1/16	20-3/8	4-13/16	8-9/16	4-13/16	9-7/8	3-1/16
4 Row	19-1/16	3-1/16	20-3/8	4-13/16	8-9/16	4-13/16	9-7/8	3-1/16

### Notes:

- 1 and 2 row coil supply and return 1/2" nominal (5/8" OD) all sizes
- Inlet grille optional
- Unit shown with left hand piping connections and right hand electrical connections as standard
- Right hand piping connections with left hand electrical connections available as an option
- Piping hand determined when facing the air outlet
- All listed dimensions are approximate and are subject to change without notice
- Modifications to the product specifications must be accepted by Zehnder Rittling at its base office
- See [www.zehnder-rittling.com](http://www.zehnder-rittling.com) for any recent updates or changes

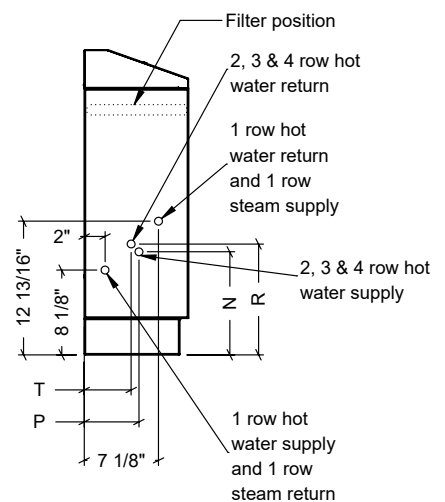

**Side view: Model RSI**

# Dimensions and data

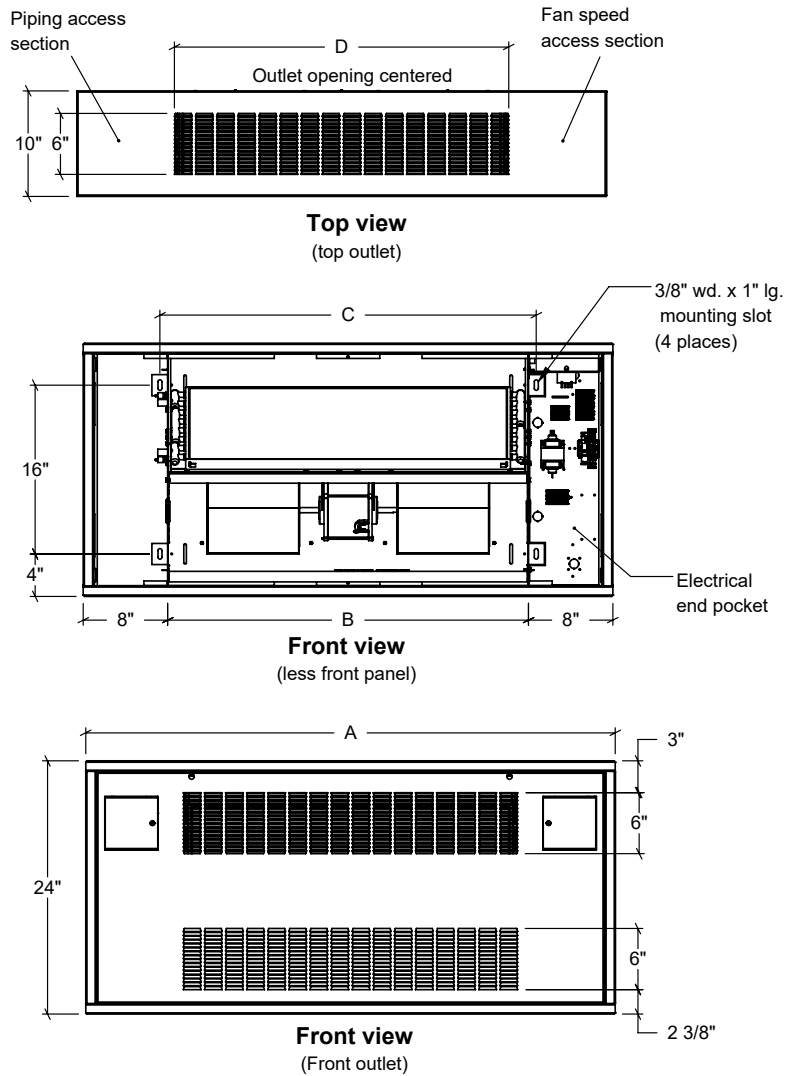

## Models RW, RWI and RC

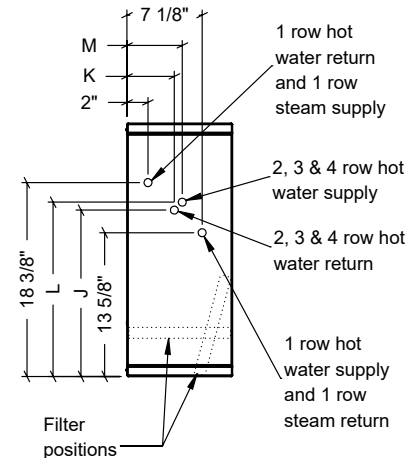
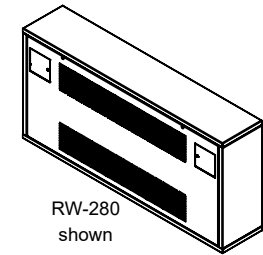
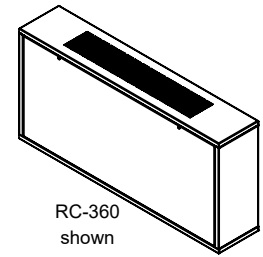

Side view: Model RW and RC

### Dimensional data

Unit size	A			B	C	Louvers		Ducted opening	
	Std.	6" Ext.	6" Ext. x2			D	E	F	G
02	38-3/16	44-3/16	50-3/16	22-3/16	24	20	6	18-3/8	5-1/8
03	44-3/16	50-3/16	56-3/16	28-3/16	30	26	6	24-3/16	5-1/8
04	50-3/16	56-3/16	62-3/16	34-3/16	36	32	6	30-3/16	5-1/8
06	62-3/16	68-3/16	74-3/16	46-3/16	48	44	6	42-3/16	5-1/8
08	68-3/16	74-3/16	80-3/16	52-3/16	54	50	6	48-3/16	5-1/8
10	76-3/16	82-3/16	88-3/16	60-3/16	62	58	6	56-3/16	5-1/8
12	86-3/16	92-3/16	98-3/16	70-3/16	72	68	6	66-3/16	5-1/8

Coil	J	K	L	M	N	P	R	T
2 Row	15-3/4	4-7/16	16-9/16	5-3/16	7-7/16	5-3/16	8-1/4	4-7/16
3 Row	16-9/16	3-1/16	17-1/8	4-13/16	6-1/8	4-13/16	4-13/16	3-1/16
4 Row	16-9/16	3-1/16	17-1/8	4-13/16	6-1/8	4-13/16	4-13/16	3-1/16

### Notes:

- 1 and 2 row coil supply and return 1/2" nominal (5/8" OD) all sizes
- Inlet grille optional
- Unit shown with left hand piping connections and right hand electrical connections as standard
- Right hand piping connections with left hand electrical connections available as an option
- Piping hand determined when facing the air outlet
- All listed dimensions are approximate and are subject to change without notice
- Modifications to the product specifications must be accepted by Zehnder Rittling at its base office
- See [www.zehnder-rittling.com](http://www.zehnder-rittling.com) for any recent updates or changes

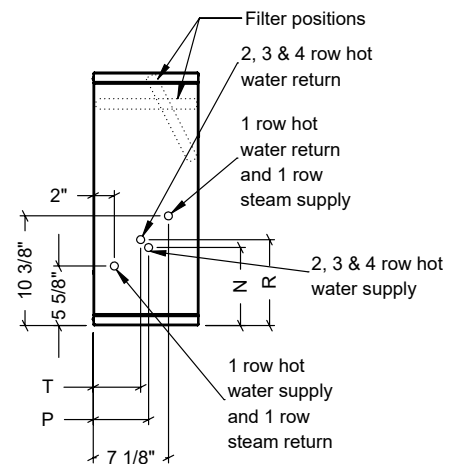

Side view: Model RWI

# Dimensions and data

## Models RRW, RFRW, RRC, RFRW, RRWI and RFRWI

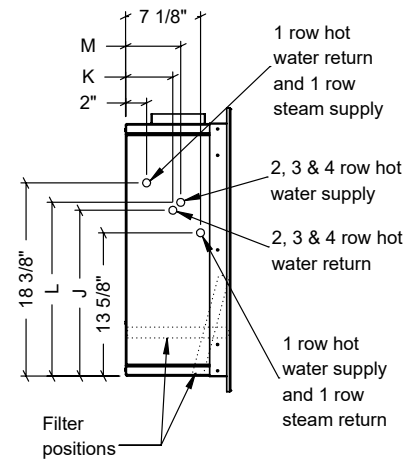
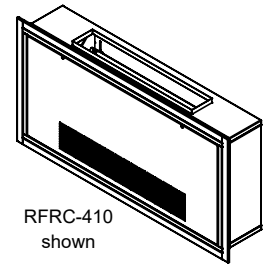
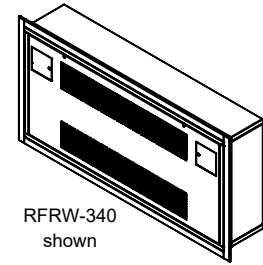
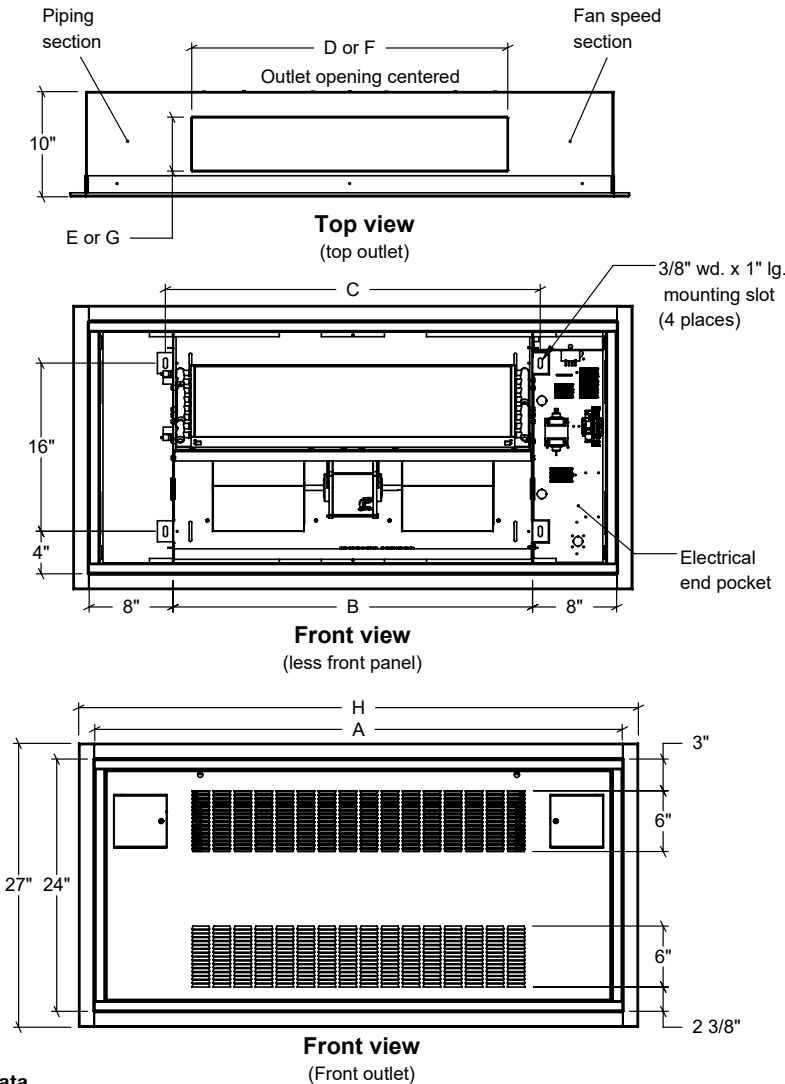

Side view: Model RRW, RFRW, RRC and RFRW

### Dimensional data

Unit size	A			B	C	Louvers		Duct opening		H		
	Std.	6" Ext.	6" Ext. x2			D	E	F	G	Std.	6" Ext.	6" Ext. x2
02	38-3/16	44-3/16	50-3/16	22-3/16	24	20	6	18-3/8	5-1/8	41-3/16	47-3/16	53-3/16
03	44-3/16	50-3/16	56-3/16	28-3/16	30	26	6	24-3/16	5-1/8	47-3/16	53-3/16	59-3/16
04	50-3/16	56-3/16	62-3/16	34-3/16	36	32	6	30-3/16	5-1/8	53-3/16	59-3/16	65-3/16
06	62-3/16	68-3/16	74-3/16	46-3/16	48	44	6	42-3/16	5-1/8	65-3/16	71-3/16	77-3/16
08	68-3/16	74-3/16	80-3/16	52-3/16	54	50	6	48-3/16	5-1/8	71-3/16	77-3/16	83-3/16
10	76-3/16	82-3/16	88-3/16	60-3/16	62	58	6	56-3/16	5-1/8	79-3/16	85-3/16	91-3/16
12	86-3/16	92-3/16	98-3/16	70-3/16	72	68	6	66-3/16	5-1/8	89-3/16	95-3/16	101-3/16

Coil	J	K	L	M	N	P	R	T
2 Row	15-3/4	4-7/16	16-9/16	5-3/16	7-7/16	5-3/16	8-1/4	4-7/16
3 Row	16-9/16	3-1/16	17-1/8	4-13/16	6-1/8	4-13/16	4-13/16	3-1/16
4 Row	16-9/16	3-1/16	17-1/8	4-13/16	6-1/8	4-13/16	4-13/16	3-1/16

### Notes:

- 1 and 2 row coil supply and return 1/2" nominal (5/8" OD) all sizes
- Unit shown with left hand piping connections and right hand electrical connections as standard
- Right hand piping connections with left hand electrical connections available as an option
- Piping hand determined when facing the air outlet
- All listed dimensions are approximate and are subject to change without notice
- Modifications to the product specifications must be accepted by Zehnder Rittling at its base office
- See [www.zehnder-rittling.com](http://www.zehnder-rittling.com) for any recent updates or changes

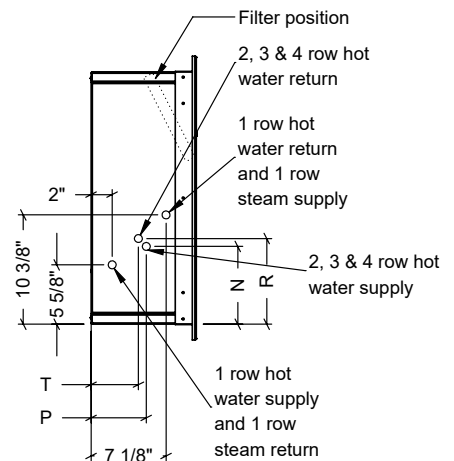

Side view: Model RRWI and RFRWI

# Dimensions and data

## Damper

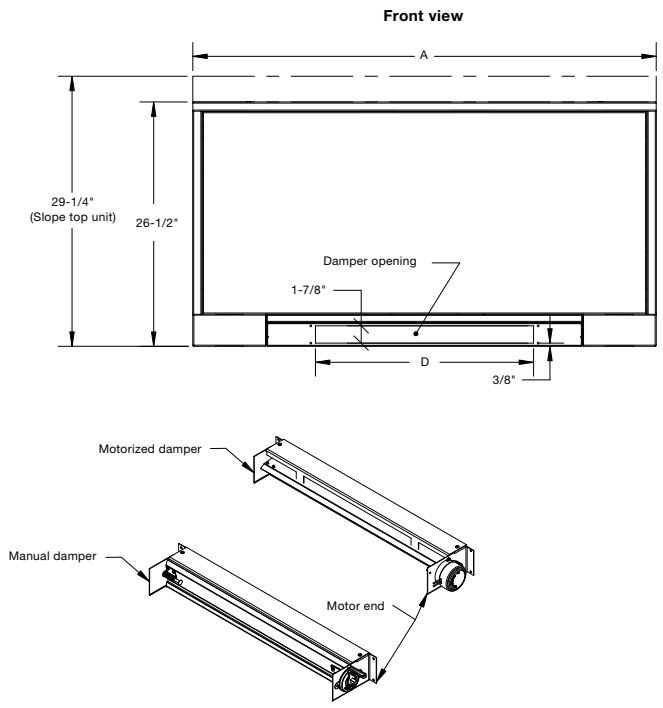

**Dimensional data**

Unit size	A	B	C	D
02	38-3/16	22-3/8	24	18-5/8
03	44-3/16	28-3/8	30	18-5/8
04	50-3/16	34-3/8	36	23-5/8
06	62-3/16	46-3/8	48	23-5/8
08	68-3/16	52-3/8	54	33-5/8
10	76-3/16	60-3/8	62	33-5/8
12	86-3/16	70-3/8	72	33-5/8

**Notes:**

- Damper motor always on right side when viewing unit from front side.
- All listed dimensions are approximate and are subject to change without notice. Modifications to the product specifications must be accepted by Zehnder Rittling at its base office.
- Available for models RF and RS only.

# Dimensions and data

## Outside air wall box

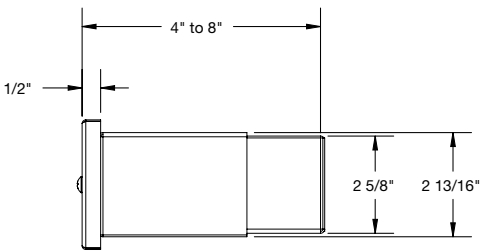
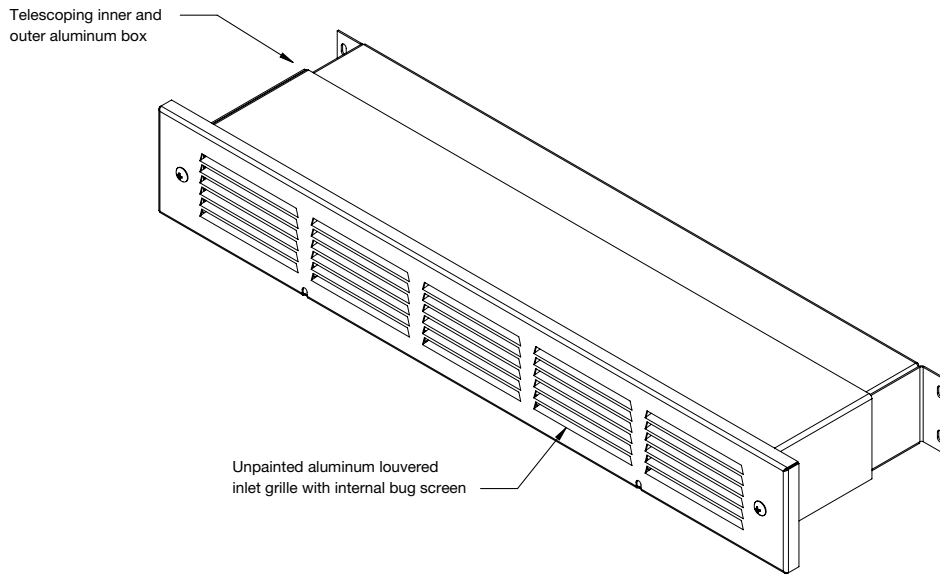

Side View

Dimensional data		
Model	A	Rough opening
WB-0203	24	22-1/2 x 3
WB-0406	29	27-1/2 x 3
WB-081012	39	37-1/2 x 3

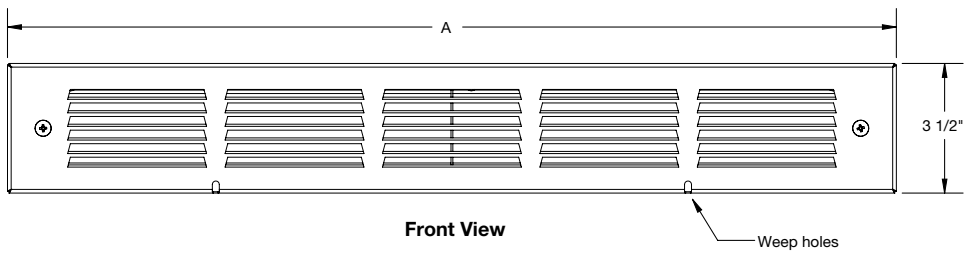

Front View

# Dimensions and data

## Wall seal kit

Ships loose for field mounting

Front view

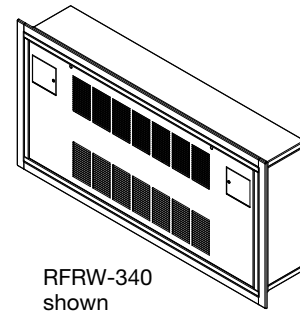
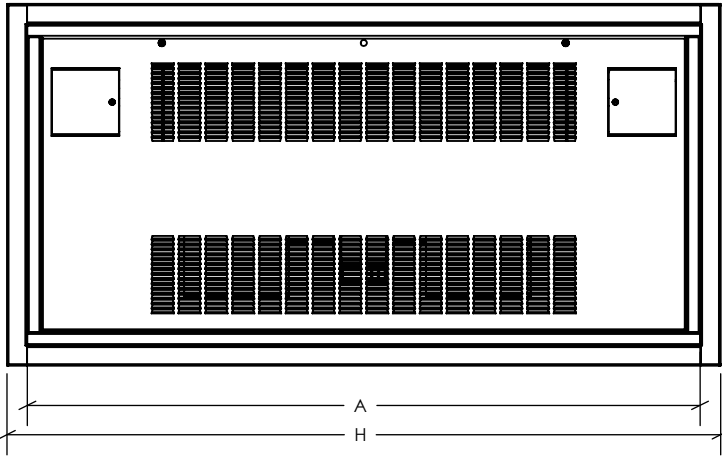

RFRW-340 shown

Top view

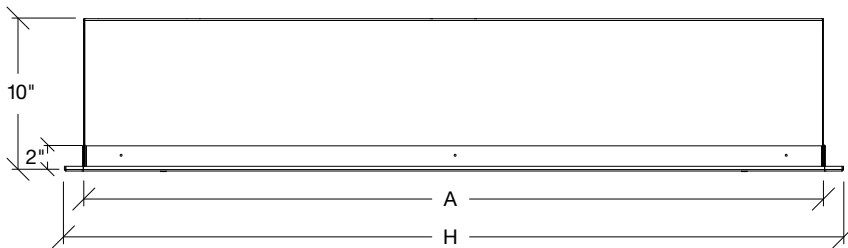

Side view

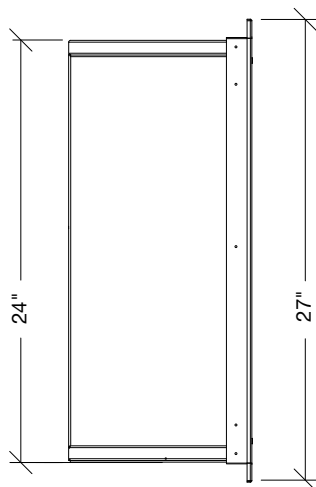

Dimensional data

Unit size	A	H
02	38-3/16	41-3/16
03	44-3/16	47-3/16
04	50-3/16	53-3/16
06	62-3/16	65-3/16
08	68-3/16	71-3/16
10	76-3/16	79-3/16
12	86-3/16	89-3/16

- For fully recessed units locate frame flush with front
- For partially recessed units locate frame as needed
- Use sheet metal screws (by others) to secure trimframe to the unit.

## General information

This installation and start-up instructions literature is for horizontal and vertical Cabinet Unit Heaters. Cabinet Unit Heaters are hydronic terminal units designed for year-round heating. Your equipment is initially protected under the Zehnder Rittling standard 2-year warranty provided the steps outlined in this manual for initial inspection, installation, periodic maintenance and normal every day operation of the equipment are followed. This manual should be thoroughly reviewed prior to the installation, start-up or maintenance of the equipment. If any questions arise, please contact your local Zehnder Rittling sales representative or the factory before proceeding any further.

There are a multitude of options and accessories available with the equipment covered in this manual. For more specific details on the included options and accessories, refer to the order acknowledgment, approved submittals and catalogs.

## Receiving

Upon delivery, examine the shipment against the bill of lading to make sure all of the units have been received and then check each unit carefully for shipping damage. Any damage should be reported to the freight carrier and a claim should be filed with them. Ensure the shipping company makes proper notation of any shortages or damage on all copies of the freight bill. Concealed damage not discovered during unloading must be reported to the shipping company within 15 days of receipt of the shipment.

All units are shipped F.O.B. factory. Therefore, Zehnder Rittling is not responsible for damage during transit. It is the responsibility of the installing contractor to inspect and verify that the units shipped were in fact the correct model number, voltage, etc. Any discrepancies should be reported to the local Sales Representative for immediate resolution prior to unpackaging and installation. The factory should be notified of any warranty repairs required in writing before any corrective action is taken. The factory must be fully informed of the expected costs before the work is begun. Zehnder Rittling is not responsible for any repairs or alterations made by the purchaser without Zehnder Rittling's written consent and will not accept any back charges associated with these repairs or alterations. The return of damaged equipment will not be accepted without written authorization from Zehnder Rittling.

A unit that has received a written Return Goods Authorization will be inspected by Zehnder Rittling upon receipt. Any damage, missing parts, reworking or repackaging resulting from prior installation will constitute just cause for Zehnder Rittling to issue partial credit.

Several components are shipped loose for field installation and to offer added protection during shipment and job site storage. These items may include; thermostat, valve packages, remote temp sensors, etc.

## Safety considerations

The installation of Cabinet Unit Heaters and all associated components, parts and accessories which make up the installation, shall be in accordance with the regulations of all authorities having jurisdiction and must conform to all applicable codes. Only trained and qualified service personnel using good judgment and safe practices should install, repair and/or service air conditioning equipment.

Untrained personnel can perform basic maintenance functions such as cleaning coils and cleaning or replacing filters. All other operations should be performed by trained service personnel. When working on air conditioning equipment, observe precautions in the literature, tags and labels attached to the equipment and all other safety precautions that may apply.

Improper installation, adjustment, alteration, service, maintenance, or use can cause explosion, fire, electrical shock or other hazardous conditions which may cause serious personal injury and/or property damage. Consult a qualified installer, service agency, or your sales representative for information or assistance.

The equipment must always be properly supported by rigging and lifting equipment. Any temporary supports used during installation or maintenance must be designed to adequately hold the equipment in place until equipment is permanently fastened and set in its final location. All supports must meet applicable local codes and ordinances.

All fastening devices must be designed to mechanically hold the assembly in place without the ability to loosen or break away due to system operation or vibration.

All power must be disconnected and locked out before any installation or service is performed to avoid electrocution or shock. More than one power source may be supplied to a unit. Power to remote mounted units may not be supplied through the unit.

Never use bulky or loose fitting clothing when working on any mechanical equipment. Gloves should always be worn for protection against heat, sharp edges and all other possible hazards. Safety glasses should always be worn, especially when drilling, cutting or working with chemicals.

Never pressurize equipment beyond specified pressures as shown on unit rating plate. Always pressure test with an inert fluid such as water or dry nitrogen to avoid possible damage or injury in the event of a leak or component failure during testing.

Always protect adjacent flammable material when welding or soldering. Use a suitable heat shield material to contain sparks or drops of solder. Have a fire extinguisher readily available.

Please follow standard safe practices regarding the handling, installing or servicing of mechanical equipment. Read these instructions thoroughly and follow all warnings or cautions attached to the equipment. Consult local building codes and the National Electrical Code(NEC) for special installation requirements.

Understand the signal words: danger, warning and caution.

### **⚠ DANGER**

Identifies the most serious hazards which will result in severe personal injury or death.

### **⚠ WARNING**

Signifies hazards that could result in personal injury or death.

### **⚠ CAUTION**

Used to identify unsafe practices, which would result in minor personal injury or product and property damage.

The manufacturer assumes no responsibility for personal injury or property damage resulting from improper or unsafe practices during the handling, installation, service or operation of the equipment. The installation of Cabinet Unit Heaters and all associated components, parts and accessories shall be in accordance with the regulations of all authorities having jurisdiction and must conform to all applicable codes. It is the responsibility of the installing contractor to determine and comply with all applicable codes and regulations.



## Unpacking and preparation

All units are carefully inspected at the factory throughout the entire fabrication and assembly processes under Zehnder Rittling's stringent quality assurance program. All major components and subassemblies such as motors, blowers, coil, controls, valve package and paint quality are carefully tested for proper operation, visually inspected and verified for full compliance with factory standards. Operational testing for some customer furnished components such as pneumatic valves and DDC controllers may be a possible exception.

Cabinet Unit Heaters are usually shipped on pallets of up to 5 units. Each unit is factory tagged according to the customer's purchase order. This allows the unit, upon removal from the pallet, to be taken directly to its' assigned space for immediate installation. Units should not be installed at locations other than that designated on the tag.

Each unit is carefully packaged in a polyethylene plastic bag for surface protection, placed in a cardboard container and filled with kraft paper padding for shipment to avoid damage during normal handling in the shipment process. It is the sole responsibility of the customer to provide the protection necessary to prevent vandalism and weather deterioration of the equipment. Under no condition should the units be left unprotected from the elements. If the equipment is not needed immediately at the job site, it should be left in its shipping carton and stored in a clean, dry area of the building or in a warehouse. Do not remove any equipment from its shipping package until it is needed for installation. The equipment is NOT suitable for outdoor installations.

After determining the condition of the cardboard container exterior, carefully remove each unit from the container and inspect for hidden damage. At this time, check that all shipped loose items such as wall mounted thermostats, aquastats, remote temperature sensors, valve package, etc., are accounted for and placed in a safe area. Any hidden damage should be recorded and immediately reported to the carrier and a claim should be filed. In the event a claim for shipping damage is filed, the unit, cardboard container, and all packing must be kept for physical inspection by the freight carrier.

Once the equipment is properly positioned on the job site, cover the units with either a shipping carton, vinyl film, or an equivalent protective covering. Cap open ends of piping that is stored on a job site. Take special care to prevent foreign materials from entering the units in areas where painting, dry walling, or spraying of fireproof material, etc., has not yet been completed as these materials may accumulate on the motors and blower wheels. Foreign material that accumulates within the units can prevent proper start-up, necessitate costly clean-up operations, or result in immediate or premature component failure. Before installing any of the system components, be sure to examine each pipe, fitting and valve, and remove any dirt or foreign material found in or on these components. All manufacturer's warranties are void if foreign material is allowed to be deposited on the motor or blower wheels of any unit. Some job conditions may require some form of temporary unit covering during construction.

### **⚠ CAUTION**

DO NOT store or install units in corrosive environments or in locations subject to temperature or humidity extremes (e.g., attics, garages, rooftops, etc.). Corrosive conditions and high temperature or humidity can significantly reduce system performance, reliability and overall service life.

# Handling and installation

While all equipment is designed for durability and fabricated with heavy gauge materials and may present a robust appearance, great care must be taken to assure that no undue force is applied to the coil, piping, or other delicate components such as control boards during handling. Wherever possible, all units should be maintained in an upright position and handled by the chassis, plenum sections or as close as possible to the mounting points. In the case of a fully exposed cabinet unit, the unit must obviously be handled by the exterior casing. Gloves should be worn when handling finished, painted units and should never be set down on unclean, hard surfaces. Failure to follow these instructions may lead to scratching or gouging of the finished surface.

Although Zehnder Rittling does not become involved with the design and selection of support methods and/or components, it should be recognized that unacceptable operating characteristics and/or performance may result from poorly implemented unit support. Additionally, proper clearance must be provided for service and removal of the equipment.

Anchoring the equipment in place is accomplished by using the mounting points provided, and positioning the unit on a LEVEL plane. Vertical units are designed to be bolted to the wall structure through the slotted wall mounting holes in the chassis, used for anchoring to pre-installed wall studs. Horizontal units are provided with slotted ceiling mounting brackets where hanging rod and rubber-in-shear or spring vibration isolators, supplied by others, can be used for proper suspension and vibration isolation.

The type of mounting device is a matter of choice, however the mounting point should always be that provided in the chassis or cabinet.

## **⚠ WARNING**

Improper mounting could result in the unit falling from its position, causing personal injury or even death.

After mounting the unit, it is then ready for the various service connections such as water and electrical. At this time it should be verified that the proper types of services are actually provided to the unit. On those units requiring hot water, the proper line size and water temperature should be available to the unit.

On units with steam heating coils, the proper line sizing and routing should be verified. The maximum steam pressure should never exceed 15 psig. The drain piping and steam trap, supplied by others, should be sized and routed to allow for proper condensate flow.

The electrical service to the unit should be compared to the unit nameplate to verify compatibility. The routing and sizing of all piping, and the type and sizing of all wiring and other electrical components such as circuit breakers, disconnect switches, etc., should be determined by the individual job requirements and should not be based on the size and/or type of connection(s) provided on the equipment. Verify the electrical conductor size is suitable for the distance to the equipment connection and will support the equipment electrical load. All installations should be made in compliance with all governing codes and ordinances. Compliance with all codes is the responsibility of the installing contractor.

Provide access clearance for electrical enclosure per local and national electrical code requirements, minimum of 36". It is recommended to leave 36" access on pipe connection side. It is also recommended to leave room for filter removal, equivalent to the physical size of the filter.

## Hot water connections

Submittals and product literature detailing unit operation, controls and connections should be thoroughly reviewed before beginning the connection of the heating medium to the unit.

All shipped loose valve packages should be installed as required and all service valves should be checked for proper operation.

All coil and valve package connections are to be made with a sweat or solder joint. Care should be taken to assure that no components in the valve package are subjected to a high temperature which may damage seals or other materials. Many two-position electric control valves, depending on valve operation, are provided with a manual opening lever. This lever should be placed in the “open” position during all soldering or brazing operations. In accordance with good soldering and brazing practices, valve bodies should be wrapped with a wet rag to help dissipate the heat.

If the valve package connection at the coil is made with a union, the coil side of the union must be prevented from twisting during tightening to prevent damage to the coil tubing. Over-tightening must be avoided to prevent distorting the union seal surface and destroying the union, ultimately causing a leak.

### **⚠ CAUTION**

Secure the union nut hand-tight and then tighten no more than an additional 1/4 turn.

The inlet supply connection is marked at the appropriate coil stub-out with the other coil stub-out being the outlet return connection.

After the connections are completed, the system should be tested for leaks. Since some components are not designed to hold pressure with a gas, hydronic systems should be tested with water. Test pressure must not exceed 250 psig. Pressure testing should be completed prior to sheet rocking, finished floors, painting, caulking, etc.

### **⚠ CAUTION**

All water coils must be protected from freezing after initial filling with water. Even if the system is drained, unit coils may still hold enough water to cause damage when exposed to temperatures below freezing.

In the event that leaking or defective components are discovered, the Zehnder Rittling Sales Representative must be notified before any repairs are attempted. All leaks should be repaired before proceeding with the installation.

After system integrity has been established, it is recommended that the piping be insulated in accordance with the project specifications. This is the responsibility of the installing or the insulation contractor. Zehnder Rittling will not accept any charges associated with re-insulating piping if the installing contractor failed to establish system integrity prior to insulating.

## Ductwork connections

All ductwork and or supply and return grilles should be installed in accordance with the project plans and specifications. If not included on the unit or furnished from the factory, supply and return grilles should be provided as recommended in the product catalog.

For units with no return air ductwork, check local code requirements for possible application restrictions. All units must be installed in non-combustible and non-hazardous areas.

Some models are designed to be connected to ductwork with a minimum amount of external static pressure. These units may be damaged by operation without the proper ductwork connected. Consult the approved submittals and the product catalog for unit external static pressure limitations.

Units provided with outside air should have some form of low temperature protection to prevent coil(s) from freezing. This protection may be a low-temperature thermostat to close the outside air damper, a preheat coil to temper the outside air before it reaches the unit, or any other protective method.

It should be noted that none of these methods will adequately protect a coil in the event of power failure. The safest method of freeze protection is to use glycol in the proper percent solution for the coldest expected air temperature.

Flexible duct connections should be used on all air handling equipment to minimize vibration transmissions. Insulation and ductwork should be installed to allow servicing of equipment including motors, blowers, filters, etc.

Zehnder Rittling assumes no responsibility for undesirable system operation due to improper design, equipment or component selection, and/or installation of base unit, ductwork, grilles and other related components.

# Electrical connections

The unit serial tag lists the unit electrical characteristics such as the required supply voltage, motor amperage and required circuit ampacities. The unit wiring diagram shows all unit and field wiring. The installer must be familiar with the wiring diagram before beginning any wiring as the wiring can change from project to project.

## **⚠ WARNING**

Electrical shock can cause personal injury or death. When installing or servicing system, always turn off main power to system. There may be more than one disconnect switch. Thermostat "OFF" should not be used for disconnect purposes.

All field wiring connecting to this type of unit must be 105 °F rated copper conductor and should be in accordance with the National Electrical Code and any applicable local codes. Branch circuit fusing and electrical disconnect means, if required, must be furnished and installed by others. All unit-mounted control components are factory wired to the junction control box located in the electrical end pocket of units. Remote-mounted control components are shipped loose for field installation and wiring and are to be wired in strict accordance with the wiring diagram. Failure to do so could result in personal injury or damage to components and will void the manufacturer warranty.

All wiring connections should be checked prior to start-up to ensure connections have not come loose during shipment or installation, minimizing problems during start-up.

The fan motor(s) should never be controlled by any wiring or device other than the factory supplied switch or thermostat/switch combination without factory authorization.

Consult the factory wiring and valve package diagrams when installing an aquastat. The switch should always be installed upstream of the control valve on a pipe that will have constant flow regardless of the control valve position, allowing a true water temperature reading at all times. A bleed bypass may be required to guarantee proper aquastat operation.

The applicable wiring diagram ships with each unit and must be strictly followed. Field power supply wiring should be through end pocket openings or knockouts in the supplied junction boxes.

All field wiring should be done in accordance with governing codes and ordinances. Any modification of the unit wiring without factory authorization will void the warranty and nullify any agency listings.

Zehnder Rittling assumes no responsibility for any damages and/or injuries from improper field installation and/or wiring.

# Wiring schematics

120V

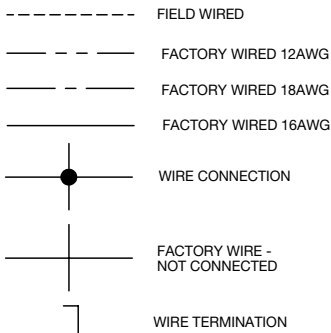
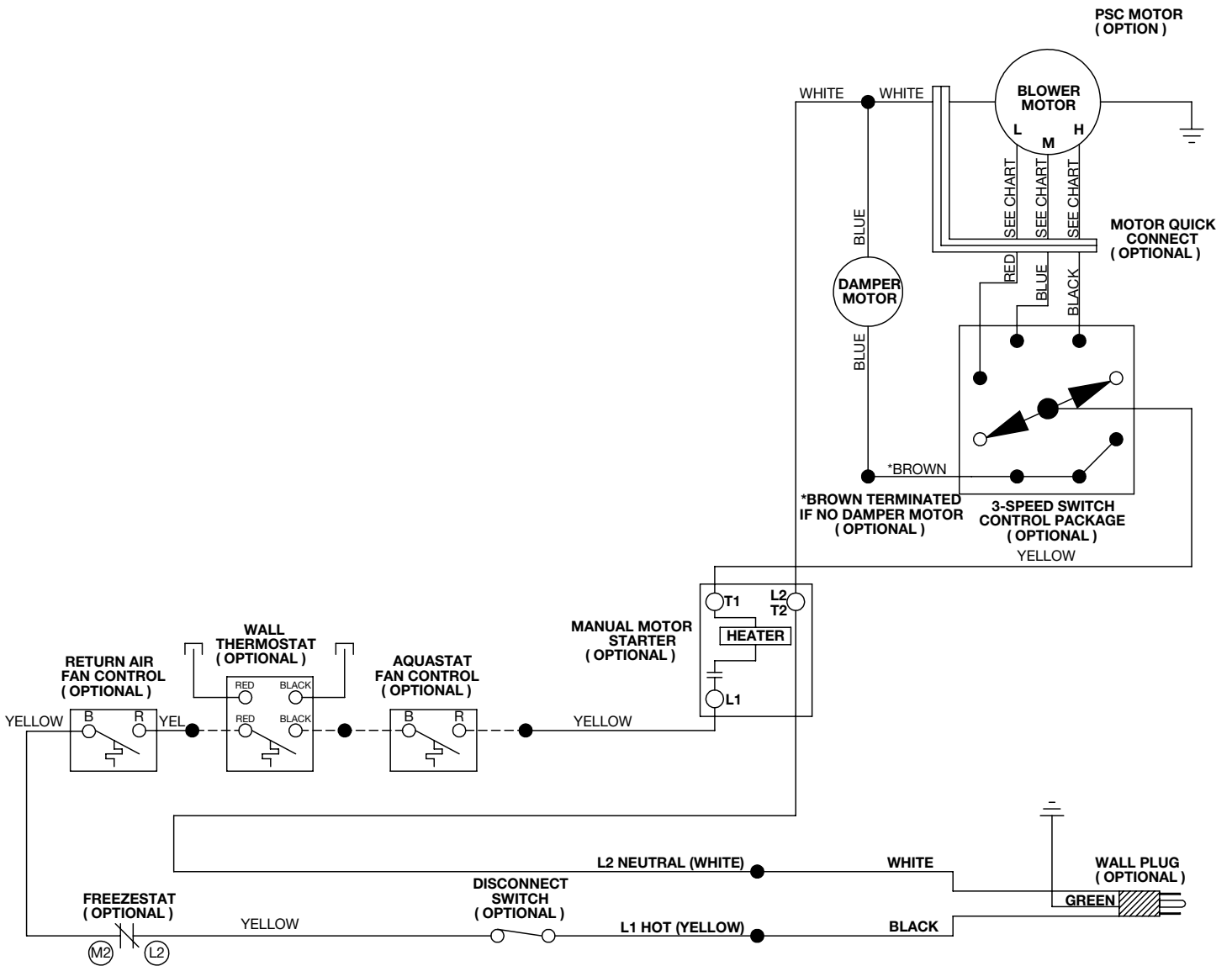

**Notes:**

- Complete the wiring in accordance with national and local codes.
- Wiring diagram is for typical application. If other controls are specified wiring may differ from what is shown.
- Models RC, RRC, RFRC units get 3 speed switches shipped loose for field wiring.

Blower motor wiring chart				
Size	Motor Sizes	High	Medium	Low
02	12W	Black	Blue	Red
03	12W	Black	Red	Yellow
04	30W	Black	Blue	Red
06	50W	Black	Red	Yellow
08	50W, 25W	Black	Red	Yellow
10	(2) 50W	Black	Yellow	Gray
12	(2) 50W	Black	Red	Yellow

**Notes:**

- For high static motors use the following 3 speed switch wiring configuration: red / low - blue / med - black / high

# Wiring schematics

208V / 240V / 277V

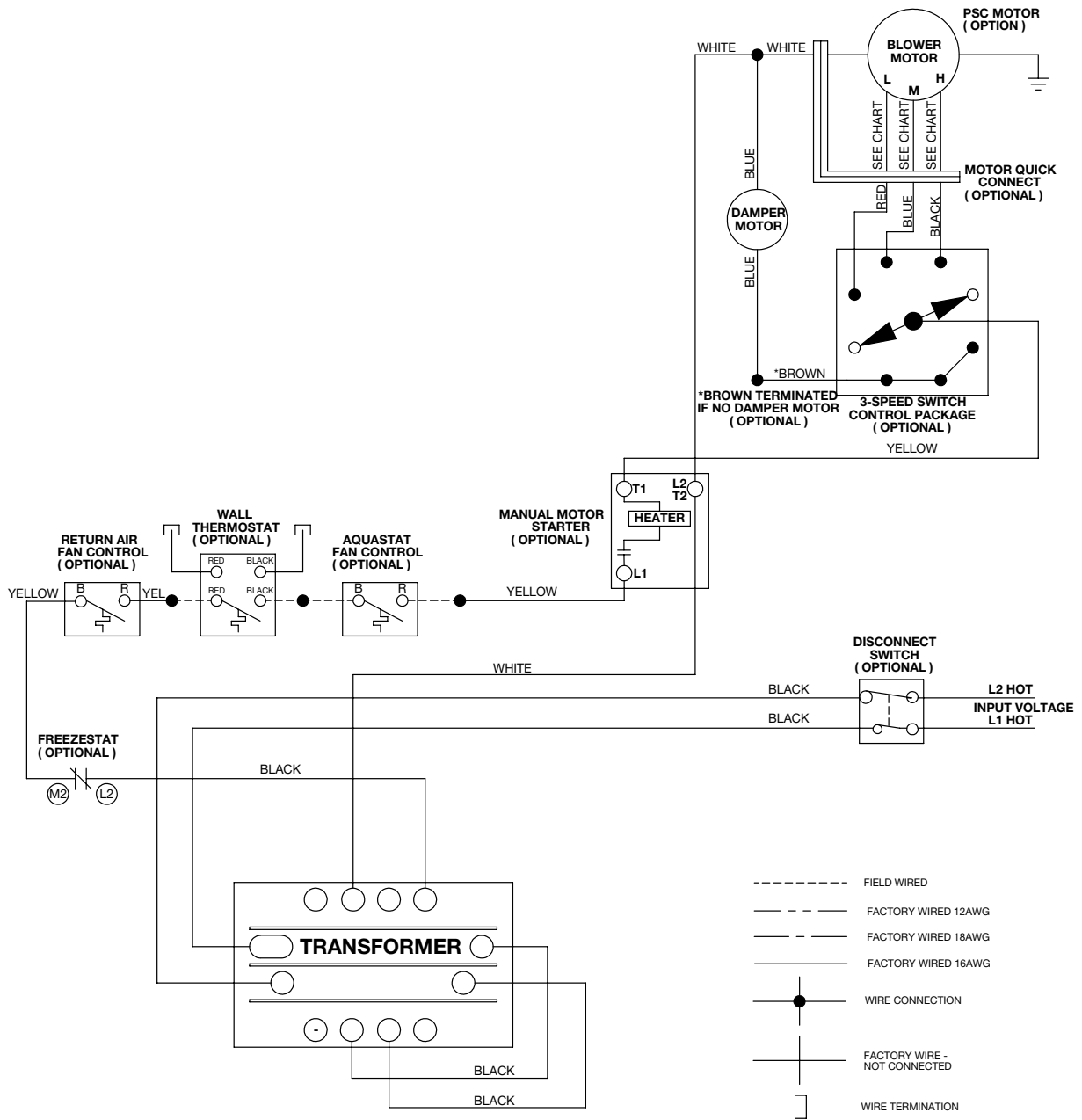

**Notes:**

- Complete the wiring in accordance with national and local codes.
- Wiring diagram is for typical application. If other controls are specified wiring may differ from what is shown.
- Models RC, RRC, RFRC units get 3 speed switches shipped loose for field wiring.
- Transformers and fuses are sized specific to CUH unit sizes.
- Wire transformer primary according to input voltage (208V/240V/277V) wire transformer secondary for 120VAC.

**Blower motor wiring chart**

Size	Motor Sizes	High	Medium	Low
02	12W	Black	Blue	Red
03	12W	Black	Red	Yellow
04	30W	Black	Blue	Red
06	50W	Black	Red	Yellow
08	50W, 25W	Black	Red	Yellow
10	(2) 50W	Black	Yellow	Gray
12	(2) 50W	Black	Red	Yellow

**Notes:**

- For high static motors use the following 3 speed switch wiring configuration: red / low - blue / med - black / high

## Start-up general

Before beginning any start-up, the start-up personnel should take the time to familiarize themselves with the unit, options, accessories and control sequence to fully understand how the unit should operate properly under normal conditions. All personnel should have a good working knowledge of general start-up procedures.

The building must be completely finished before attempting to start-up the equipment, including doors, windows and insulation. All internal doors and walls should be in place. In some cases, the internal decorations and furniture may influence overall system performance. The entire building should be as complete as possible before beginning any system balancing.

The initial step is to visually inspect all of the equipment, plenums, connecting ductwork and piping. Ensure that all systems are properly installed and supported and that all construction debris or foreign objects have been removed from the equipment.

Each unit should be checked for:

- Free blower wheel operation
- Loose wires
- Loose or missing access panels or doors
- Filter installed, clean and of the proper size and type
- Proper ductwork is attached
- Supply and return grilles are in place and secure

Except as required during start-up and balancing, no Cabinet Unit Heaters should be operated without all the proper ductwork attached, supply and return grilles in place and all the access doors and panels secured in place.

### **⚠ CAUTION**

Failure to do so could result in damage to the equipment or building and furnishings and will void the manufacturer's warranty.



---

## Air system balancing

All ductwork must be complete and fully connected. All return and supply grilles, filters and access doors and panels must be properly installed before air balancing to ensure that the system is being balanced at the true system operating conditions.

Each individual unit and its attached ductwork is a unique system with its own operating characteristics. Because of this, air balancing is generally done by a trained balance specialist who is familiar with the procedures required to properly establish the fan system and air distribution operating conditions. This should not be attempted by unqualified personnel.

After proper system operation is established, the actual unit air delivery and the actual fan motor amperage draw for each unit should be measured and recorded for future reference.

## Heating system

Prior to the water system start-up and balancing, the hot water system should be thoroughly flushed to clean out dirt and debris which may have accumulated in the piping during construction. During this procedure, all unit service valves must be in the closed position. This will prevent any foreign material from entering the unit's heat exchanger and clogging valves and metering devices. Strainers should be installed in the piping mains to prevent this material from entering the units during normal operation.

During system filling, air venting from the unit is accomplished by the use of the standard, manual air vent or the optional automatic air vent that is installed at the top of each coil's header. Manual air vents are capped Schrader valves. To vent the air from the coil, unscrew the cap, turn the cap over and insert the pointed end of the cap into the vent to depress the valve until all of the air has been vented from the coil. When water begins to escape from the vent, release the valve and replace the cap. Automatic air vents may be unscrewed one turn counterclockwise to speed up the initial venting but should be screwed in for automatic venting during normal operation.

### **⚠ CAUTION**

The air vents provided are not intended to replace the main system air vents and may not release air trapped in other parts of the system. Inspect the entire system for potential air traps and independently vent those areas as required. In addition, some systems may require repeated venting over time to fully eliminate air in the system.

## Water system balancing

A complete knowledge of the hydronic system, including its components and controls, is essential to proper water system balancing and should only be completed by a qualified expert. The system must be complete, and all components must be in operating condition before beginning the water system balancing procedures.

Each hydronic system has different operating conditions depending on the devices and controls installed for the particular application. The actual balancing technique may vary from one system to another.

After the proper system operation is established, the appropriate operating conditions such as water temperatures, flow rates and pressure drops should be recorded for future reference.

Before and during water system balancing, conditions may exist due to incorrect system pressures which may result in noticeable water noise or undesired valve operation. After the entire system is balanced, these conditions will not exist on properly designed systems. If any of these conditions persist, recheck the system for air that may not have been properly vented during start-up.

## Water treatment

Proper water treatment is a specialized industry and therefore it is recommended to consult an expert in this field to analyze the water for compliance with the water quality parameters listed below and to specify the appropriate water treatment program. The expert may recommend rust inhibitors, scaling preventative, antimicrobial growth agents or algae preventatives. Anti-freeze solutions, glycols, may also be used to lower the freezing point.

All Zehnder Rittling water coils are constructed of copper tubes and headers while multiple brass and bronze alloys may be present in the valve packages. It is the end user's responsibility to ensure that any of the water delivery components are compatible with the treated water.

Failure to provide proper water quality will void the Cabinet Unit Heater's warranty.

Water content	Required concentration
Sulphate	< 200 ppm
pH	7.0 – 8.5
Chlorides	< 200 ppm
Nitrate	< 100 ppm
Iron	< 4.5 mg/L
Ammonia	< 2.0 mg/L
Manganese	< 0.1 mg/L
Dissolved solids	< 1000 mg/L
Calcium carbonate hardness	300 – 500 ppm
Calcium carbonate alkalinity	300 – 500 ppm
Particulate quantity	< 10 ppm
Particulate size	800 micron max

---

## Controls operation

Before proper control operation can be verified, all other systems must be operating properly. The correct water and air temperatures must be present to determine if the control function is operating to design. Some controls and features are designed to not operate under certain conditions.

A wide range of controls, electrical options and accessories may be used with the units covered in this manual. Review the approved project submittals or order acknowledgment for detailed information regarding each individual unit and its controls. Since controls may vary from one unit to another, care should be taken to identify the controls being used with each individual unit and its proper control sequence.

## Exposed unit touch-up and repainting

Exposed cabinet units will be furnished with an epoxy powder coated paint finish. Small scratches in the finish may be repaired with touch-up spray paint available from the factory.

### **▲ CAUTION**

Proper safety procedures should be followed regarding ventilation and personal safety equipment when using spray paint. Follow the manufacturer's directions for the products being used.

To repaint the factory powder coat finish, prepare the surface by lightly sanding with #280 grit sand paper or #000 or #0000 fine steel wool. The surface may also be wiped with a liquid surface etch cleaning product. These items should be available at most paint product stores. It should be noted that the more care taken during this process, the more effective it will be.

After this preparation is finished, the factory finish should provide excellent adhesion for a variety of air dried top coats. Enamel will give a more durable, higher gloss finish, while latex will not adhere as well and will give a dull, softer finish. Top coats involving an exothermic chemical process between two components such as epoxies and urethanes should be avoided.

All standard colors including primer can be painted over. If the installing contractor chooses not to paint over the primer color, the factory cannot match primer color on future orders, potentially causing color match issues in the field.

Factory touch-up spray paint may require a number of light coats to isolate the factory finish from the quick drying touch-up paint.

# Normal operation and periodic maintenance

## General

Each unit on a project will have its own unique operating environment and conditions which dictate a maintenance schedule for that unit that may be different from other equipment on the project. A formal regular maintenance schedule and an individual unit log should be established and maintained. Following this schedule will help maximize the performance and service life of each unit on the project.

The safety considerations listed in the front of this manual should be followed during any service and maintenance operations.

For more detailed service information consult your Sales Representative or the factory.

### **▲ WARNING**

Disconnect power supply from the unit before servicing.

## Motor/blower assembly

The type of fan operation is determined by the control components and their method of wiring. This may vary from unit to unit. Refer to the wiring diagram located in a zip-lock plastic bag in the electrical end pocket of each unit for that unit's individual operating characteristics.

All motors have permanently lubricated bearings so no further field lubrication is ever required.

If the motor/blower assembly ever requires more extensive service such as motor or blower wheel/housing replacement, the entire assembly can be removed from the unit.

Dirt and dust should not be allowed to accumulate on the blower wheel or housing. Failure to keep this clean may result in an unbalanced wheel condition which can lead to a damaged blower wheel or motor. The wheel and housing may be cleaned periodically using a brush and vacuum cleaner, taking care not to dislodge the factory applied balancing weights on the blower wheel blades. Clean the blower at every inspection. Any blower or motor that is not properly maintained will not be covered under the manufacturer's warranty.

## Coil

Coils may be cleaned by removing the motor/blower assembly, providing access to the air entry side of the coil. Brush the entire finned surface with a soft bristled brush, brushing parallel to the fins, taking care not to damage the fins. Brushing should be followed by cleaning with a vacuum cleaner. Compressed air can also be used by blowing air through the coil fins from the leaving air side, again followed by vacuuming. If fins are damaged during the cleaning process, a 12 fins per inch fin comb can be used to straighten the fins. For a deeper cleaning, spray the finned surface with a mild alkali cleaning solution and rinse thoroughly. Failure to maintain a clean coil surface will result in reduced airflow, reduced performance and increased power consumption. Clean the coil at every inspection. Units provided with the proper type of air filters, replaced regularly, will require less frequent coil cleaning.

## Electrical wiring & controls

Electrical operation of each unit is determined by the components and wiring of the unit. This may vary from unit to unit. Refer to the wiring diagram located in a zip-lock plastic bag in the electrical end pocket of each unit for the actual type and number of controls provided on each unit.

The integrity of all electrical connections should be verified at least twice during the first year of operation. Afterwards, all controls should be inspected regularly for proper operation. Some components may experience erratic operation or failure due to age. Thermostats may become clogged with dust/lint, and should be periodically inspected and cleaned to provide reliable operation.

When replacing any electrical components such as fuses, contactors, relays or transformers, use only the exact type, size and voltage component as furnished from the factory. Any deviation from this could result in personnel injury or damage to the unit and will void the manufacturer's warranty. All repair work should be done in such a way as to maintain the equipment in compliance with governing local and national codes, ordinances and safety testing agency listings.

---

## **Valves and piping**

No formal maintenance is required on the valve package components other than a visual inspection for possible leaks during normal periodic unit maintenance. Strainers, when included, should be checked regularly for build-up and rinsed as needed. In the event that a valve should need replacement, the same precautions taken during the initial installation to protect the valve package from excessive heat should be implemented during replacement.

## **Throwaway filters**

These types of filters should be replaced on a regular basis. The time interval between replacement is dependent upon the environment in which the unit is operating and should be set established based on regular inspection of the filter. Record the time interval in the maintenance log for future reference. Refer to the product catalog for the recommended filter size. If the replacement filters are not purchased from the factory, the same type and size filters should be obtained. Pleated media or extended surface filters should not be used without consent from the factory due to the high air pressure drops associated with these types of filters, negatively affecting unit performance.

## **Cleanable filters**

Cleanable filters should be inspected and cleaned on a regular basis, similar to the maintenance schedule used for throwaway filters. The time interval between cleaning is dependent upon the environment in which the unit is operating and should be established based upon regular inspection of the filter. Record the time interval in the maintenance log for future reference. Unlike throwaway filters, cleanable filters may be cleaned and reinstalled in the unit instead of being disposed of when dirty. The cleanable filters may be washed in hot, soapy water and then set aside to dry before recharging and reinstalling.

Before replacing the filter, it should be recharged with some type of entrapment film such as “Film-Car Recharging Oil.” The filter should be sprayed on both sides or submerged in the film to assure complete coverage. The filter should not be soaked in the film but should be quickly dunked and removed, allowing the excess to drain off the surface before reinstalling in the unit.

Note: cleanable filters tend to have less air pressure drop than throwaway filters.

## Replacement parts

Factory replacement parts should be used wherever possible to maintain unit performance, it's normal operating characteristics and its safety testing agency listings.

Replacement parts may be purchased through the local Zehnder Rittling Sales Representative.

Contact the local Sales representative or factory before attempting any unit modifications. Any modifications not authorized by the factory could result in personnel injury, damage to the unit, and will void the manufacturer's warranty.

When ordering parts, the following information should be supplied to ensure proper part identification:

- Complete unit model number
- Unit serial number
- Complete part description including any identifying numbers on the part

On warranty replacements, it is often necessary to return the faulty component to receive credit. Contact the local Sales Representative who will get authorization from the factory including an RGA (Returned Goods Authorization) to be used when sending components back for inspection. Any returned components sent back to the factory without the proper RGA attached will cancel any outstanding credit.

## Equipment start-up checklist

### Receiving and inspection

- Unit received undamaged
- Unit received complete as ordered
- Unit arrangement and handing is correct
- Unit structural support is complete and correct

### Handling and installation

- Mounting grommets/isolators are used
- Unit mounted level and square
- Proper access is provided for unit and accessories
- Proper overcurrent protection is provided
- Proper service switch/disconnect is provided
- Proper hot water line sizes to unit
- All services to unit in code compliance
- All shipping screws and braces are removed
- Unit protected from dirt and foreign matter

### Heating connections

- Protect valve package components from excessive heat
- Mount valve packages
- Connect field piping to unit
- Pressure test all piping for leaks
- Insulate all piping, as required

### Ductwork connections

- Install ductwork, fittings and grilles, as required
- Flexible duct connections at unit
- Proper supply and return grille type and size
- Control outside air for freeze protection
- Insulate all ductwork, as required

### Electrical connections

- Refer to unit wiring diagram
- Connect incoming power service or services
- Install and connect "shipped loose" components

### Unit start-up

- General visual inspection and system inspection
- Check for free and proper fan rotation
- Record electrical supply voltage and amperage draw
- Check all wiring for secure connections
- Close all unit isolation valves
- Flush water systems
- After system has been flushed, ensure all isolation valves are open

**zehnder**

always the  
best climate

Always the best climate for

# SMART IDEAS

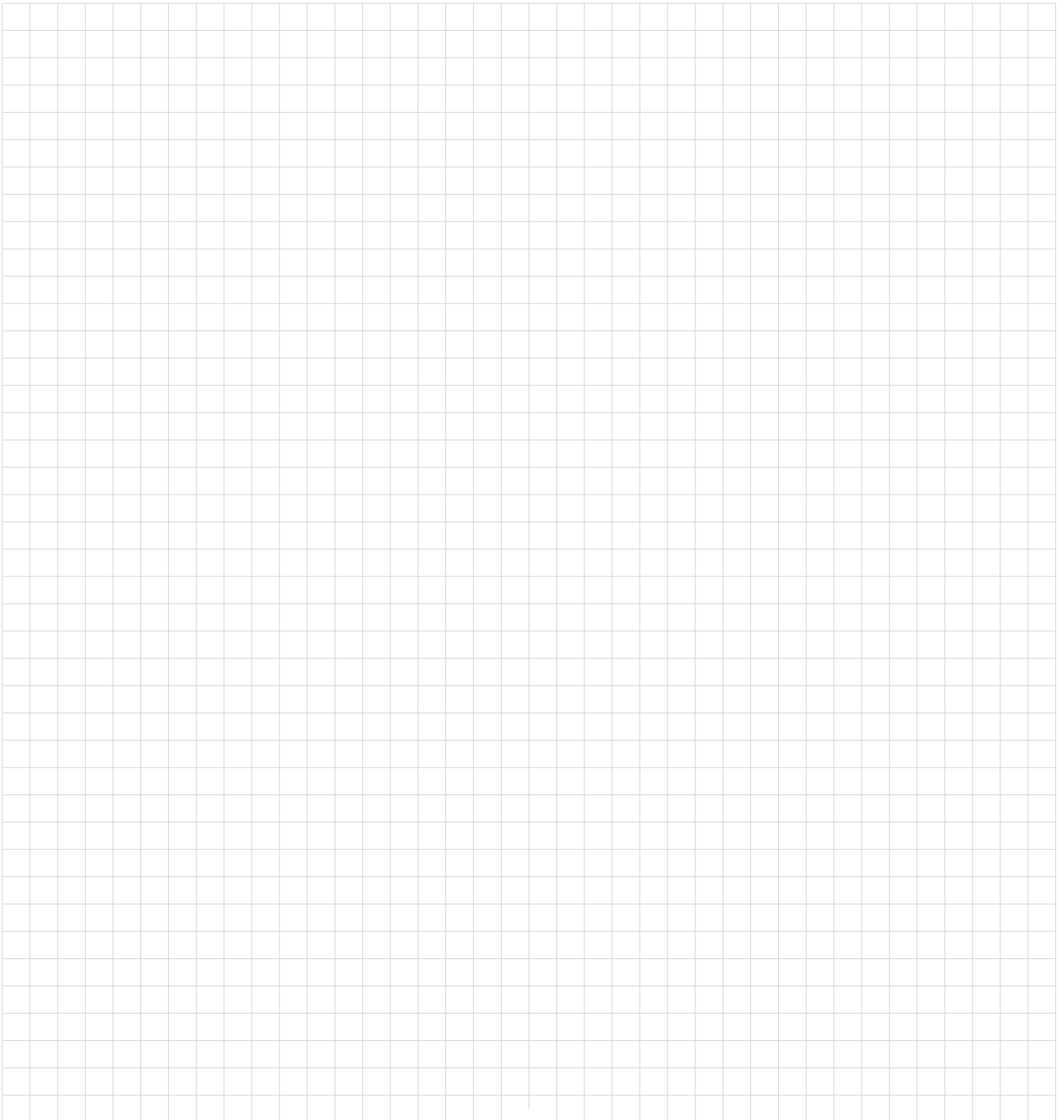

The brand  
with the  
best indoor  
climate  
solutions.

## FOUR COMPLEMENTARY PRODUCT LINES

The broad and clearly structured portfolio from the Zehnder Group is split into four product lines. Consequently, we can provide the right product, the perfect system and the matching service for all types of projects - from new builds to renovations, single- or multiple- family homes, as well as commercial projects. This variety ensures that our wealth of experience is continuously expanding, providing tangible added value to our customers on a daily basis.



### Decorative radiators

Our individual decorative radiators for living and bathrooms not only make a home warmer but also more attractive. Created by renowned designers, they impress with excellent functionality.

## NUMBERS THAT SPEAK FOR THEMSELVES

MANUFACTURER OF THE

**1<sup>ST</sup>**

STEEL RADIATOR IN  
THE WORLD

**121**

YEARS OF INNOVATIVE TRADITION

AROUND

**3,000**

EMPLOYEES

FOUNDED IN

**1895**

REPRESENTED IN  
COUNTRIES

**19**

**1,800,000**

TONNES OF CO<sub>2</sub> SAVED SINCE 2005

## WARRANTY

Zehnder guarantees its products to be free from defects in material and workmanship for a period of two years from date of shipment from our factory.

Should there be any defects in the good(s), the purchaser should promptly notify Zehnder. Upon receipt of written consent from Zehnder, the purchaser shall return the defective good(s) to the factory for inspection with freight prepaid. If inspection shows the goods to be defective, Zehnder will at its discretion repair or replace the said item(s).

Defects arising from damage due to shipment, improper installation, negligence or misuse by others are not covered by this warranty.





### Comfortable indoor ventilation

Our comfortable indoor ventilation is energy-efficient and provides a healthy indoor climate. It promotes the well-being of the occupants and increases the value of the property.



### Heating and cooling ceiling systems

Zehnder heating and cooling ceiling systems are convenient and energy-efficient for heating and cooling. They are perfectly attuned to the relevant environment.



### Clean air solutions

Clean air solutions from Zehnder reduce the level of dust in the air, create a healthier working climate and reduce the amount of cleaning required.

## BEST CLIMATE IN THE WORLD

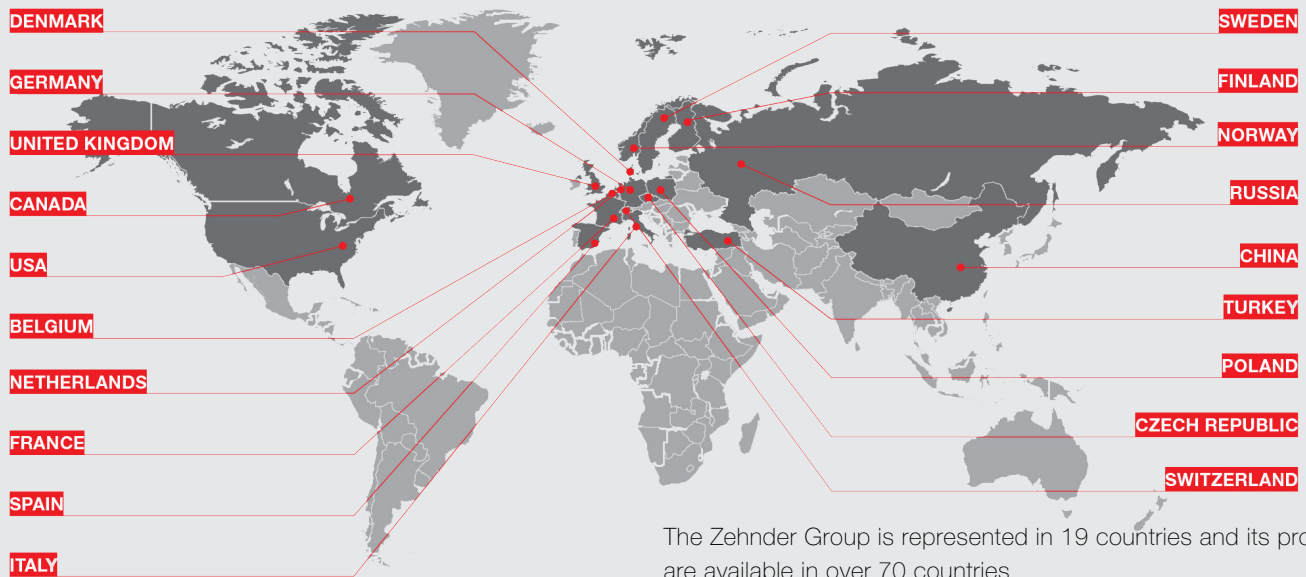

This warranty is extended only to the original purchaser from Zehnder.

**IMPORTANT: Approved submittal documentation, specific to each project, supersedes the general guidelines contained within this document.**

**zehnder**

The Zehnder brand offers excellent indoor climate solutions within the sectors of decorative radiators, clean air solutions, comfortable indoor ventilation and heating and cooling ceiling systems.

